



RP90 Plus Card Printer and RL90 Card Laminator:

User guide

October 2006

Part Number 570024-001 Rev A

Please note and heed the WARNING and CAUTION labels that have been placed on the equipment for your safety. Please do not attempt to operate or repair this equipment without adequate training. See “Safety” on page vii for the basic safety tips to ensure safe operation and maintenance of this equipment.

Regulatory compliance

These Datacard Group products conform to regulatory requirements as specified in North America, Europe, and Asia. See “Regulatory compliance” on page 78 for more information.

Trademark acknowledgments

Datacard and ID Works are registered trademarks of DataCard Corporation.
All other trademarks are the property of their respective owners.

Proprietary Notice

All drawings and information herein are the property of DataCard Corporation. The design and information contained in these materials are protected by US and international copyright laws.

Revision Log: RP90 Plus and RL90 User Guide

Revision	Date	Affected Pages	Description of Changes
A	October 2005	All	First RP90 Plus Release

Contents

Liability statement	vii
Safety	vii
Safe environment	vii
Safe human interface	vii
1 Introduction	1
About this manual	1
Who to call for assistance	1
About the Printer	2
The outside of the printer.	2
The inside of the printer.	3
The back of the printer.	4
About the laminator	5
The parts of the laminator.	5
2 Using the printer	7
Load Supplies	8
Load cards.	8
Load ink ribbon	9
Load retransfer film	10
Load laminate	11
Power on	12
Check the PC connection	12
Optional laminator connection.	13
Power on the laminator	14
LCD sequence on laminator startup.	14
Power on the printer	15
LCD sequence on printer startup	15
Prepare to print cards.	16
Initialize the ink ribbon	16
Set the retransfer film type	16
Initialize the retransfer film.	17
Initialize the patch or topcoat material (optional RL90 laminator only)	17
Printing cards	18
Print cards using ID software.	18
Print from a PC application	19
3 Viewing and changing printer settings	21
Printing Preferences.	22
Printing Properties	23

Status Monitor	24
Status tab	24
Printer Setting tab	25
Retransfer tab	26
Bend Remedy tab	26
Media Setting tab	27
Property tab	27
Others tab	28
Status monitor messages	28
Using the LCD menus	32
About the Printer LCD panel	32
Using the Printer LCD panel	33
About the Laminator LCD panel	36
Using the Laminator LCD panel	37
4 Taking care of your printer	39
Cleaning the printer	40
Cleaning the card cleaning rollers	40
Card feed roller	40
Cleaning the card feed rollers and heat roller	41
Cleaning the magnetic head	42
Cleaning the thermal head	43
Cleaning printer fan filters	43
Cleaning the laminator	44
Run a laminator cleaning card	44
Cleaning the laminator cartridge	45
Laminator fan filter	45
5 Messages and error recovery	47
Printer roller layout	47
Printer error recovery	48
Hopper jam	48
Turnover jam	49
Retransfer section jam	50
Mending broken ink ribbon or retransfer film	51
Bend remedy	52
Bend remedy printer settings	52
Bend remedy laminator settings	53
Printer LCD messages	54
Laminator error recovery	58
Card jam	58
Laminator LCD messages	60

6 Supplies	63
Ink ribbon, retransfer film, and laminator material	64
Ink ribbon	64
Retransfer film	64
Laminator material	64
Cards	64
Card size	65
Card material	65
Cleaning supplies	65
7 Site requirements	67
Site guidelines	68
Operating environment	68
Ventilation clearance	69
Storage Environment for supplies	69
Printer specifications	70
Laminator specifications	71
A Magnetic Stripe Encoding	73
Inline Encoding	74
Example	74
Character Code Table	75
B Compliance (FCC)	77
Regulatory compliance	78
Notice for USA (FCC notice)	78
Notice for Canada	78
Notice for Europe	78
Notice to Users of Printers Equipped with Contactless Smart Card	78

Liability statement

This Datacard® product has been built to the high standards of DataCard Corporation (doing business as Datacard Group). Please note and heed the WARNING and CAUTION labels that have been placed on the equipment for your safety. PLEASE DO NOT ATTEMPT TO OPERATE OR REPAIR THIS EQUIPMENT WITHOUT ADEQUATE TRAINING. ANY USE, OPERATION OR REPAIR IN CONTRAVENTION OF THIS DOCUMENT IS AT YOUR OWN RISK. BY ACCEPTANCE OF THIS SYSTEM YOU HEREBY ASSUME ALL LIABILITY CONSEQUENT TO YOUR USE OR MISUSE OF THIS EQUIPMENT. DATACARD CORPORATION SHALL NOT BE LIABLE FOR ANY INCIDENTAL, INDIRECT, SPECIAL OR CONSEQUENTIAL DAMAGE OF ANY KIND. Equipment specifications, applications and options are subject to change at the sole discretion of DataCard Corporation without notice.

Safety

All Datacard® products are built to strict safety and reliability specifications in accordance with UL60950 and Canadian requirements, and the Low Voltage Directive 73/23/EEC. Therefore, safety issues pertaining to operation and repair of Datacard® equipment are primarily environmental and human interface.

The following basic safety tips are given to ensure safe installation, operation and maintenance of Datacard® equipment and are not to be considered as comprehensive on all matters of safety.

Safe environment

- Connect equipment to a grounded facility power source. Do not defeat or bypass the ground lead.
- Place the equipment on a stable surface (table) and ensure floors in the work area are dry and non-slip. Insulated rubber floor mats are preferred.
- Know the location of equipment branch circuit interrupters or circuit breakers and how to turn them on and off in case of emergency.
- Know the location of fire extinguishers and how to use them. ABC type extinguishers may be used on electrical fires.
- Know local procedures for first aid and emergency assistance at the customer facility.
- Use adequate lighting at the equipment.
- Maintain the recommended range of temperature and humidity in equipment area.
- Keep paper and foreign materials off the printer and optional laminator.
- Keep all dust, dirt, food, liquids, etc. away from the printer at all times.

Safe human interface

- Use proper lifting techniques when moving or installing the equipment.
- Use standard electrostatic discharge (ESD) precautions when working on or near electrical circuits.

Introduction

1

About this manual

This manual provides detailed information about the Datacard® RP90 Plus card printer and the optional Datacard® RL90 card laminator. The first section provides operators with basic information about the printer and laminator including drawings and parts identification. The second section provides the information needed to use the printer, and the third section talks about viewing and changing printer settings including printing preferences and setting properties. Detailed error recovery information is provided in section five and includes LCD messages and how to recover from them. Printer supplies, storage information, and specifications are included in section six.

Who to call for assistance

If you work with a Datacard-authorized dealer, distributor, or value-added reseller, contact them for assistance. A value-added reseller provides the RP90 Plus printer and optional RL90 laminator as part of an overall system.

If any contents of the box are missing, contact your Datacard-authorized dealer, distributor or reseller. If you purchased your printer directly from Datacard, contact the Datacard Customer Care Center at 1.800.328.3996 for service in the United States and Canada. For worldwide service, call the Datacard Customer Care Center directly at 952.988.2316. Make sure you have the printer serial number, located on the back of the printer and optional laminator serial number, when you call.

About the Printer

The Datacard® RP90 Plus card printer uses retransfer printing technology to produce high-quality, edge-to-edge printing on one or both sides of a variety of PVC and non-PVC card surfaces, including contact and contactless smart cards. The retransfer printing process uses two ribbon types –a color ink ribbon and a retransfer film. The ink ribbon is available in YMCK (Yellow, Magenta, Cyan, and Black) or YMCKK format. The printer uses these colors to print images on the retransfer film, and a heat roller to transfer the image onto a card. The printer can be equipped with optional magnetic stripe and smart card capabilities.

The outside of the printer

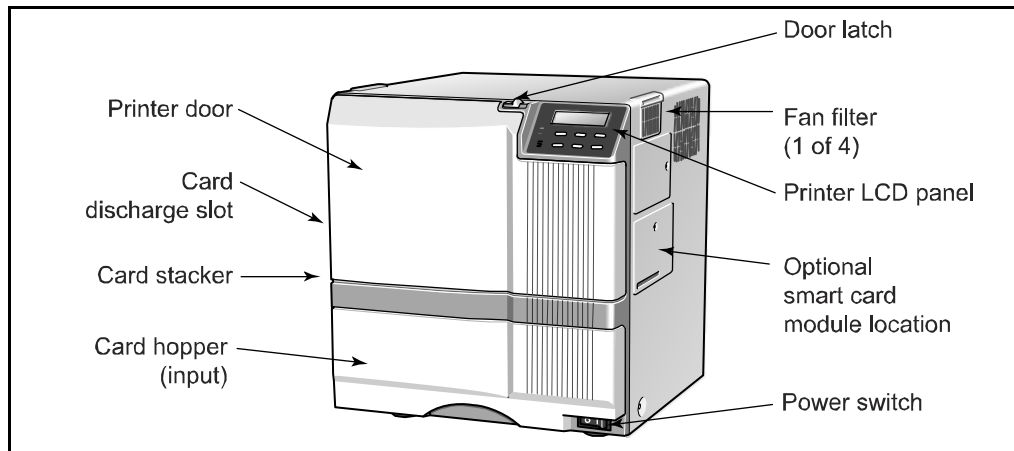

Printer door	Open the door to access the ink ribbon and retransfer film cartridges.
Printer LCD panel	Shows the printer status and any messages. Use it to change printer settings. (You can also use the driver Status Monitor, if installed, to change some printer settings.)
Door latch	Slide the latch to the right to open the printer door.
Card hopper	Load blank cards.
Power switch	Press the switch to power on the printer.
Fan filter	Helps reduce airborne contaminants entering the printer.
Card discharge slot	Cards removed from the print area exit here. If the optional RL90 laminator is installed, cards exit the printer and enter the laminator here.
Smart card module	An optional smart card module is available.
Card stacker	Printed cards exit here. If the optional laminator is installed, the card stacker is attached below the laminator's card discharge slot.

The inside of the printer

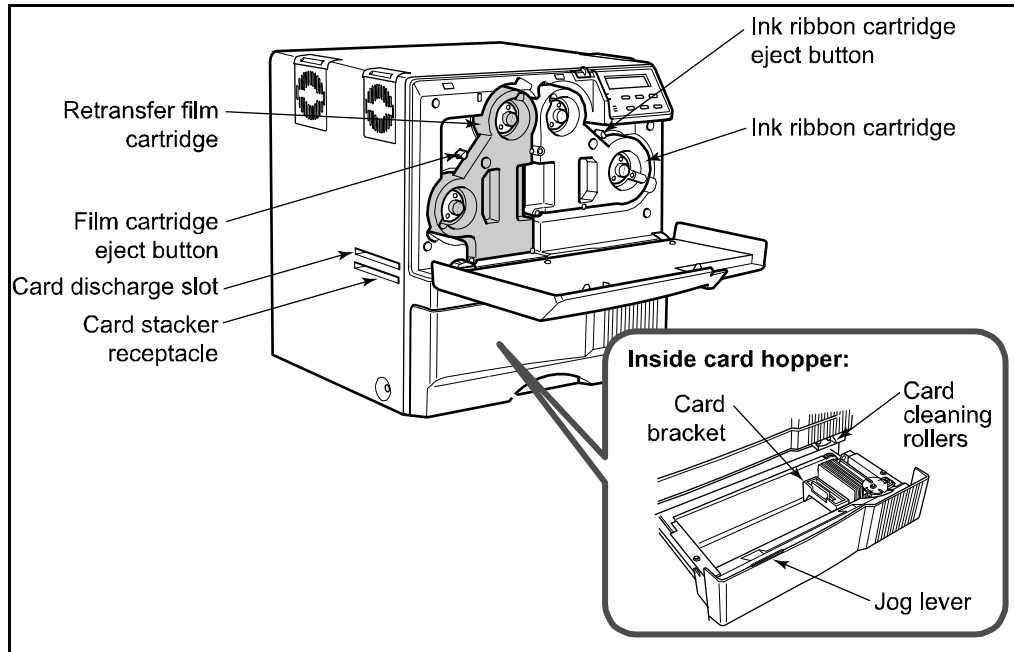

Retransfer film cartridge	Holds the retransfer film.
Film cartridge eject button	Press to release and remove the retransfer film cartridge.
Ink ribbon cartridge	Holds the ink ribbon.
Ribbon cartridge eject button	Press to release and remove the ink ribbon cartridge.
Card discharge slot	Cards removed from the print area exit here. If the optional RL90 laminator is installed, cards exit the printer and enter the laminator here.
Card stacker receptacle	Attach the card stacker here.
Card cleaning rollers	Removes dust or debris from the cards before printing.
Jog lever	Used to turn the jog wheel when clearing a card jam.
Card bracket	Slide to the left to load cards and to the right to hold cards in position.

The back of the printer

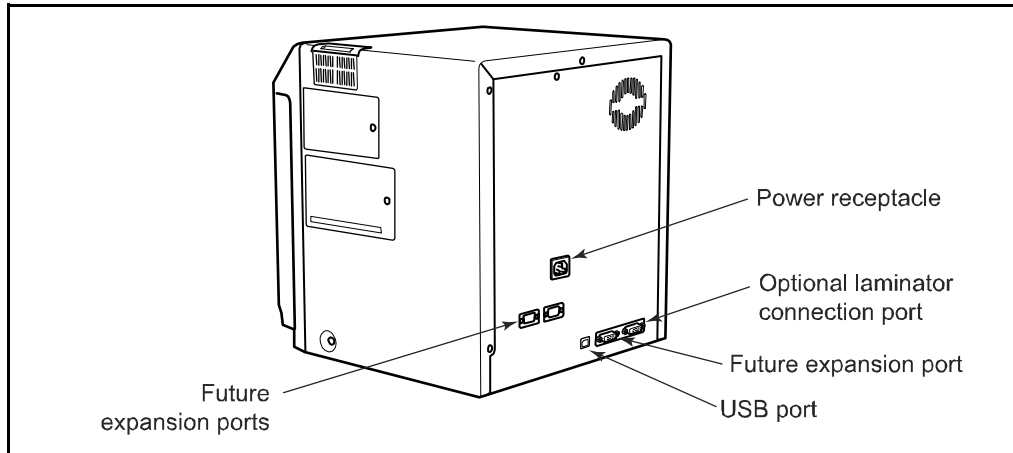

Power receptacle	Plug in the power cord.
USB port	Plug in the USB cable.
Laminator connection port	Used to connect the optional laminator module or other optional equipment.
Future expansion ports	Not used at this time.

CAUTION:
Do not connect or disconnect the laminator cable while the printer or laminator are powered on.

About the laminator

The Datacard® RL90 card laminator is an optional laminating module that works with the RP90 Plus printer to add topcoat or patch material to printed cards. Holographic laminating material is also available for added security and tamper resistance. A printed card can be laminated manually by simply inserting it into the laminator, or automatically by transferring the printed card from the RP90 Plus printer to the laminator module.

The parts of the laminator

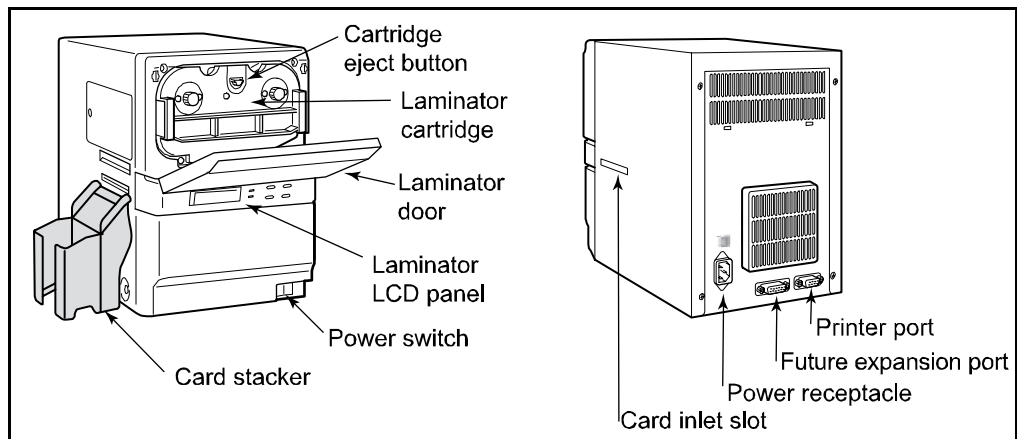

Laminator door	Open the door to access the laminator cartridge.
Laminator cartridge	Holds the laminate material.
Cartridge eject button	Press to release and remove the cartridge.
Laminator LCD panel	Shows the laminator status and any messages. Use it to change laminator settings.
Power switch	Press the switch to power on the laminator.
Power receptacle	Plug in the power cord.
Printer port	Connection port for the printer.
Card stacker	Laminated cards exit here.
Future expansion port	Not used at this time.
Card inlet slot	Cards enter the laminator here.

CAUTION:

Do not connect or disconnect the laminator cable while the printer or laminator are powered on.

Using the printer

2

This section describes how to perform basic tasks required to operate the Datacard® RP90 Plus printer and the Datacard® RL90 card laminator. It describes how to:

Load supplies

- [“Load cards” on page 8](#)
- [“Load ink ribbon” on page 9](#)
- [“Load retransfer film” on page 10](#)
- [“Load laminate” on page 11](#)

Power on

- [“Check the PC connection” on page 12](#)
- [“Optional laminator connection” on page 13](#)
- [“Power on the laminator” on page 14](#)
- [“Power on the printer” on page 15](#)

Prepare to print cards

- [“Initialize the ink ribbon” on page 16](#)
- [“Set the retransfer film type” on page 16](#)
- [“Initialize the retransfer film” on page 17](#)
- [“Initialize the patch or topcoat material \(optional RL90 laminator only\)” on page 17](#)

Print cards

- [“Print cards using ID software” on page 18](#)
- [“Print from a PC application” on page 19](#)

Begin with the printer set up and the printer driver installed. This printer must be installed by Datacard authorized and trained personnel. If the printer is not set up, contact your service provider.

Load Supplies

Load cards

Tips: Handling cards

- Do not open the card hopper when “Loading” is displayed on the LCD panel.
- Do not touch the surface of cards before printing them. (Oils on hands will reduce printing quality.)
- Handle cards by the edges or wear cotton gloves.
- Cards can stick together. Slide or fan cards to separate the edges.
- Orient all cards the same way.
- Do not use cards that are bent or otherwise damaged.
- See “Supplies” on [page 63](#) for specific card information.

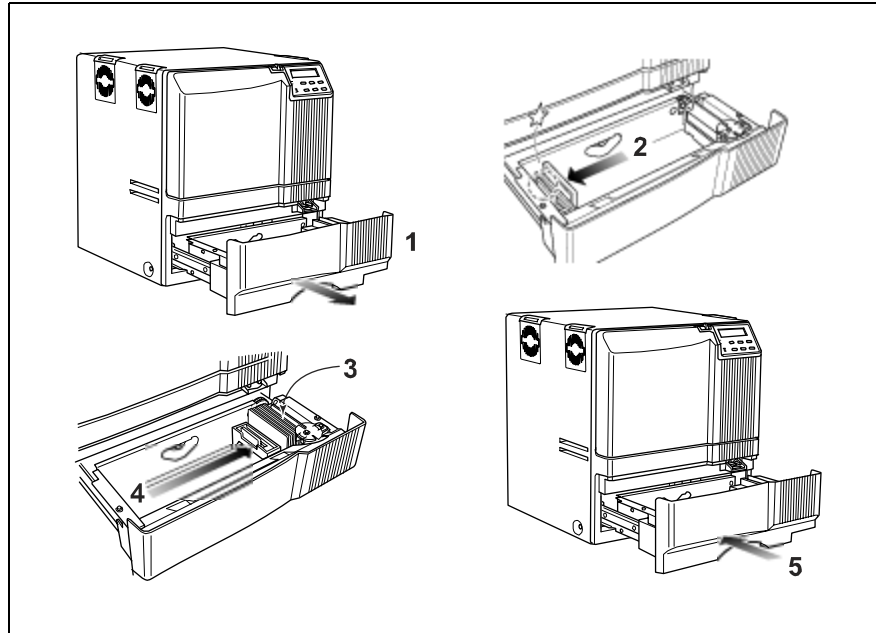

The card hopper can hold approximately 250, .030” (.75mm) cards. The cards are loaded and held in position with a card bracket. Make sure that magnetic stripe or smart cards are loaded in the proper orientation for processing.

- 1 Open the card hopper.
- 2 Slide the card bracket to the left until it latches.
- 3 Insert cards. See the diagrams below for the correct card orientation.
 - Load magnetic stripe cards with the magnetic stripe down and facing the card bracket.
 - Load smart cards with the smart card chip toward the back of the card hopper, facing the card feed roller.
- 4 Slide the card bracket back into position carefully so cards are not disturbed and your fingers do not get pinched.
- 5 Close the card hopper.

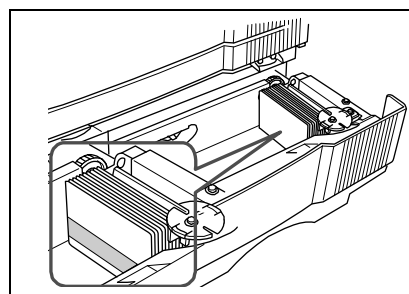

Magnetic stripe card orientation

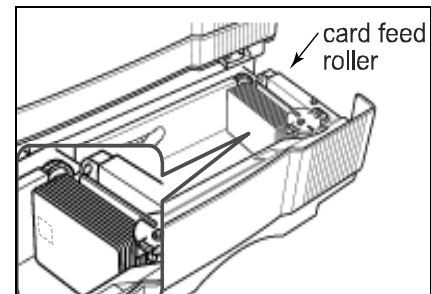

Smart card chip orientation

Load ink ribbon

Tips: Handling ink ribbon

- Do not touch the printing surface of the ink ribbon. (Oils on hands will reduce printing quality.)
- Place the cartridge on a smooth level surface when loading or reloading.
- Keep unused ink ribbon in the original package until ready for use.
- Initialize the ink ribbon each time you remove and replace the ink ribbon cartridge. See [“Initialize the ink ribbon” on page 16](#).
- See [“Storage Environment for supplies” on page 69](#) for information on storing ink ribbon.
- See [“Ink ribbon” on page 64](#) for more information about ink ribbon supply.

- 1 Slide the door latch to the right and open the printer door.
- 2 Press the ink ribbon cartridge eject button to remove the orange cartridge.
- 3 Remove both used ribbon spools from the cartridge (if present).
- 4 Load the new roll of ink ribbon on the cartridge:
 - a Put the full spool of ribbon on the orange supply spindle as shown.
 - b Put the empty take-up spool on the black take-up spindle.
 - c Align ribbon along the three ribbon guides.
 - d Take up any slack by turning the supply knob clockwise. The supply knob must be pulled out slightly to turn. If slack cannot be removed, check that the supply and take-up spools are firmly seated on the spindles.
- 5 Replace the loaded ribbon cartridge in the printer until it clicks into position.
- 6 Close the printer door.

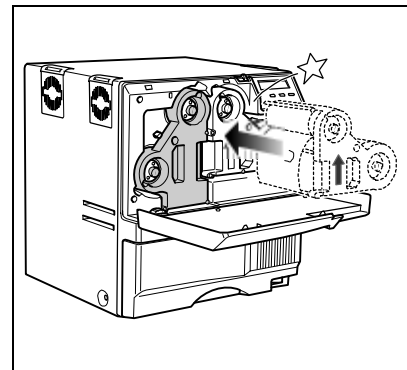
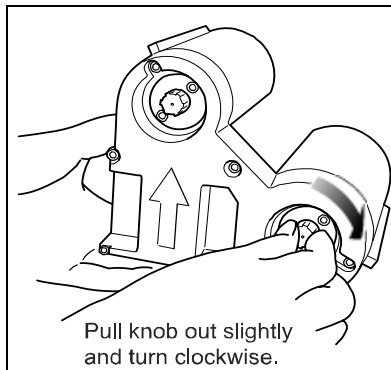
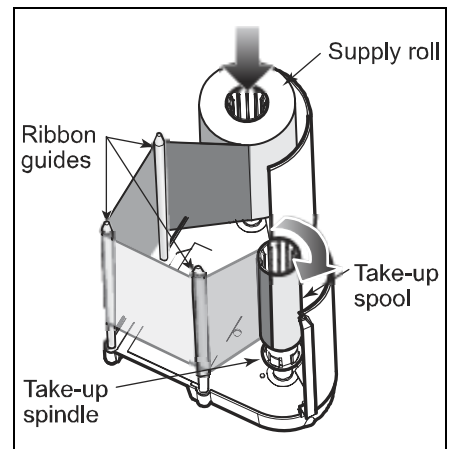
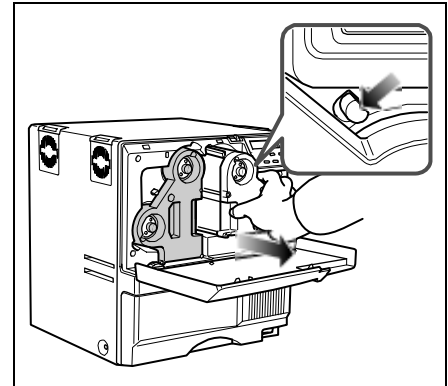

Load retransfer film

Tips: Handling retransfer film

- Place the cartridge on a smooth level surface when loading or reloading.
- Do not touch the printing surface of the retransfer film. (Oils on hands will reduce printing quality.)
- After powering on the printer, the retransfer film must be initialized. See [“Initialize the retransfer film” on page 17](#) for more information.
- Keep unused film in the original package.
- Don't place film on a dusty or dirty surface — dirt can affect print quality.
- When the retransfer film has run out, “Media Run Out” appears on the LCD panel. After replacing it, press the RESET key and then the ENTER key to initialize the film.
- See [“Retransfer film” on page 64](#) for more information about retransfer film.

- 1 Slide the door latch to the right and open the printer door.
- 2 Press the retransfer film cartridge eject button to remove the green cartridge.
- 3 Remove both used film spools from the cartridge (if present).
- 4 Load the new roll of retransfer film on the cartridge:
 - a Put the full roll of film on the green supply spindle as shown.
 - b Put the empty take-up spool on the black take-up spindle.
 - c Align the retransfer film along the three film guides.
 - d Wind two frames of film onto the take-up spool.
 - e Take up slack by turning the supply knob clockwise. The supply knob must be pulled out slightly to turn. If slack cannot be removed, check that the supply and take-up spools are firmly seated on the spindles. To ease installation, the film must be tight along the film guides. Turning the supply and take-up knobs will help maintain the proper tension.
- 5 Replace the loaded retransfer film cartridge in the printer until it clicks into position.
- 6 Close the printer door.

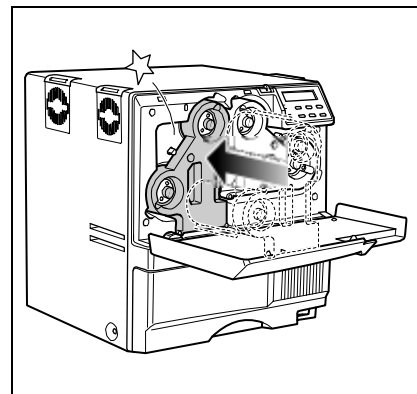
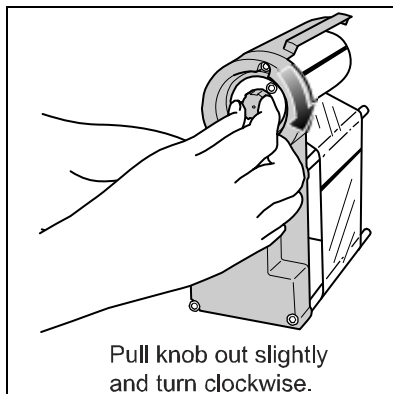
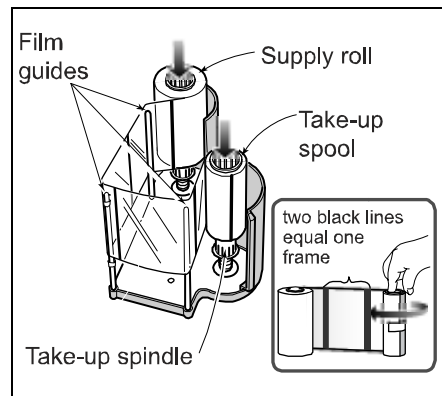
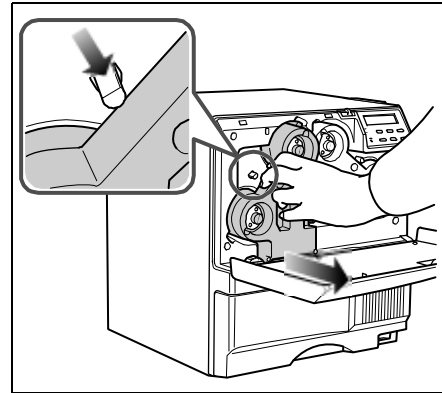

Load laminate

Tips: Handling patch or topcoat material

- After powering on the laminator, the patch or topcoat material must be initialized. Press the laminator's RESET/↑ and then the ENTER keys to initialize the material.
- The inside of the laminator contains hot surfaces. Use care when working in these areas.
- Keep unused laminating material in the original package.
- Don't place material on a dusty or dirty surface — dirt can affect card quality.
- During the laminating process, do not turn the power switch off, open the laminator door, or unplug the laminator.
- See [“Laminator material” on page 64](#) for more information about laminating material.

1 Open the laminator door by pulling the top of the door toward you.

2 Press the laminator cartridge eject button and remove the laminator cartridge carefully. The material must be tight when removing the cartridge.

3 Place the roll of material and empty take-up spool side by side on a clean surface.

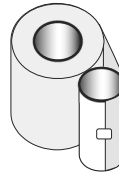

4 Remove the label from the patch or topcoat material and use it to secure the free end of the material to the empty take-up spool, making sure the edges are even.

5 Load the new roll of material on the cartridge:

a Put the full roll of material on the supply spindle.

b Put the empty take-up spool on the take-up spindle.

c Align the material along the four metal guides as shown on the cartridge label.

d Wind two or three rotations of film onto the take-up spool. Take up slack between the spools by turning the supply knob clockwise. If slack cannot be removed, check that the supply and take-up spools are firmly seated on the spindles.

6 Replace the loaded laminator cartridge in the laminator until it clicks into position.

7 Close the laminator door.

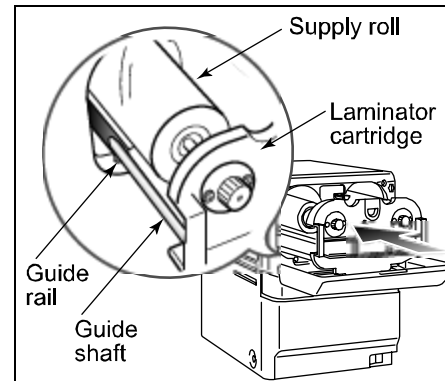
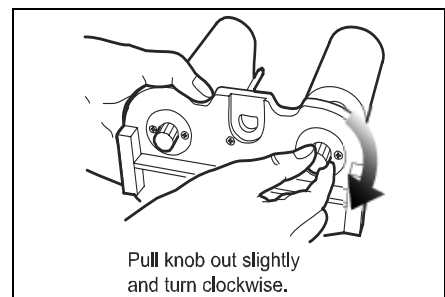
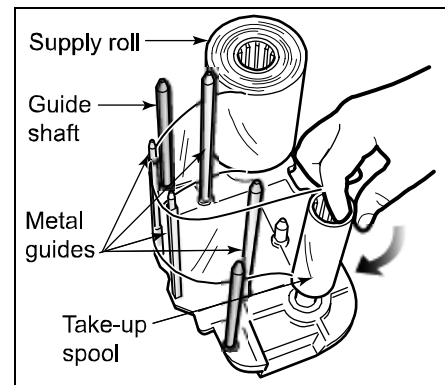
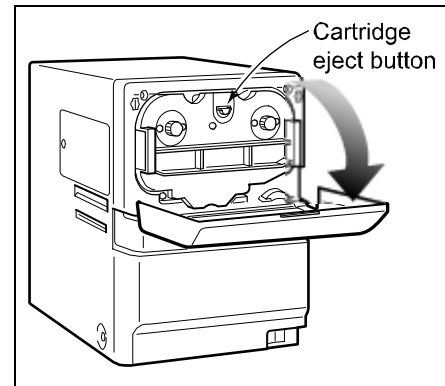

Power on

Check the PC connection

The printer and PC are connected when the printer is set up. To avoid receiving error messages on the LCD panel, make sure that all supplies are properly loaded and in position before powering on the printer. Before you begin processing cards, check the following:

- The printer door and card hopper are closed securely.
- The USB data cable (with ferrite bead) is securely connected to the printer and the PC.
- The power cable is securely connected to the printer and appropriate grounded power source.
- The card stacker is attached to the printer or to the optional laminator.
- Make sure cards and all other supplies are loaded. See [“Load Supplies” on page 8](#) for more information.

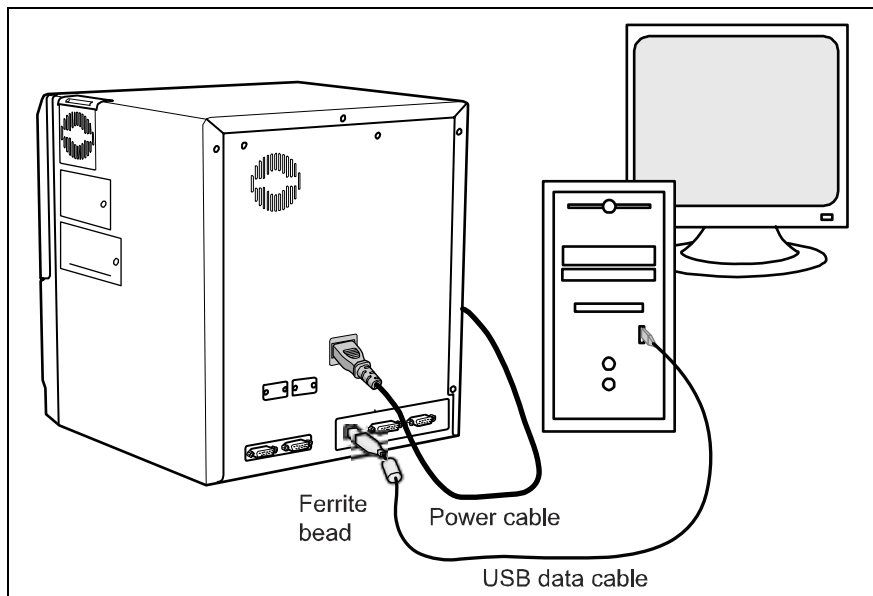

Optional laminator connection

When using the optional RL90 laminator, check the following:

- The optional laminator cable is securely connected to the printer and the laminator.
- The power cord is connected to the laminator and appropriate grounded power source.
- Supplies are loaded and the laminator door is closed securely.

CAUTION:
Always power off the printer and laminator
before you connect or disconnect the
laminator cable.

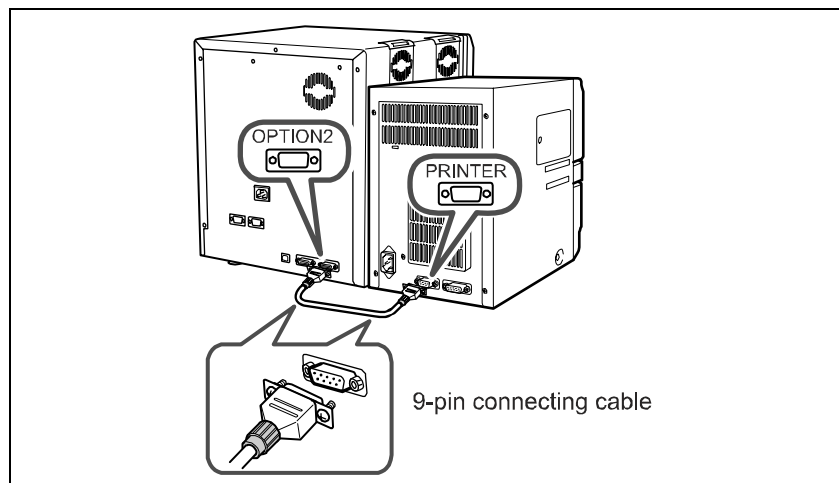

Power on the laminator

Tips for laminator power

- When connected to a printer, laminator messages will not be displayed until the printer is powered on.
- Wait while the laminator initializes.
- Follow the guidelines for your organization about when to power the laminator on and off.
- Check that the red INLET switch, located on the back of the laminator, is set for your input voltage.

When the optional RL90 laminator is installed, turn the laminator power on before powering on the printer.

- 1 Press the "I" symbol on the laminator power switch.
- 2 The laminator powers on. The LCD panel displays "Initializing" and the green Ready light blinks.
- 3 "Preheating" is displayed for approximately four minutes while the heat roller warms to operating temperature.
- 4 The LCD panel shows "Ready" and the Ready light is steady green when the laminator is ready to process cards.

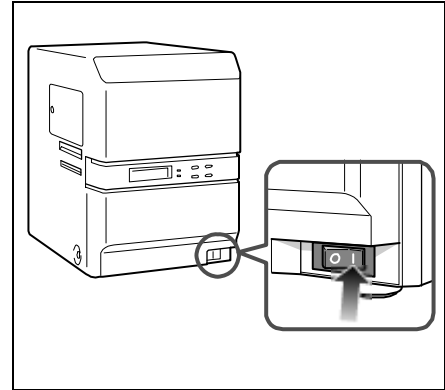

LCD sequence on laminator startup

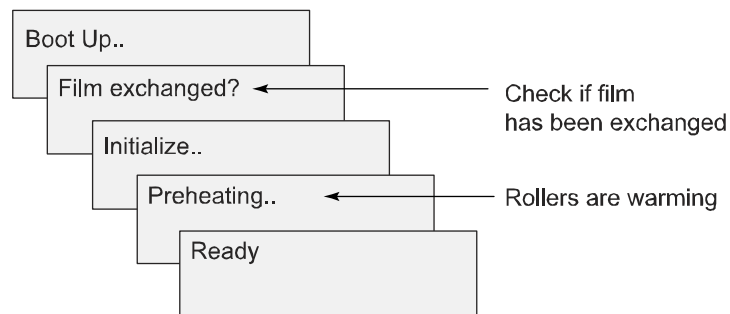

Power on the printer

Tips for printer power

- To avoid receiving errors on the LCD panel, make sure that all supplies are properly loaded and in position before powering on the printer.
- Wait while the printer initializes.
- Follow the guidelines for your organization about when to power the printer on and off.

- 1 Press the "I" symbol on the power switch.
- 2 The printer powers on. The LCD panel shows the firmware version and the printer begins initializing. The LCD panel shows "Initializing" while the printer checks and positions the ink ribbon and retransfer film.
- 3 When operation checks are complete, "Preheating" is displayed on the LCD panel for approximately four minutes while the retransfer roller and bend remedy roller warm to their operating temperatures.
- 4 The LCD panel shows "Ready" and the Ready Light is steady green.
- 5 The first time you print cards, initialize the ink ribbon. See ["Initialize the ink ribbon" on page 16](#) for the steps to follow.
- 6 The first time you print cards, set and initialize the retransfer film. See ["Set the retransfer film type" on page 16](#) and ["Initialize the retransfer film" on page 17](#) for the steps to follow.

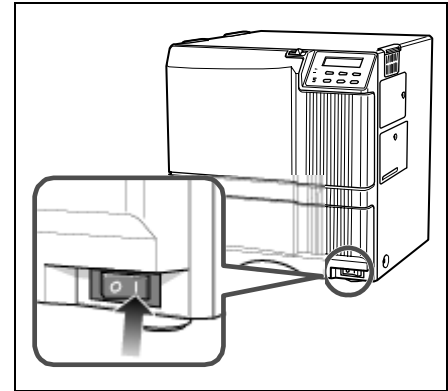

LCD sequence on printer startup

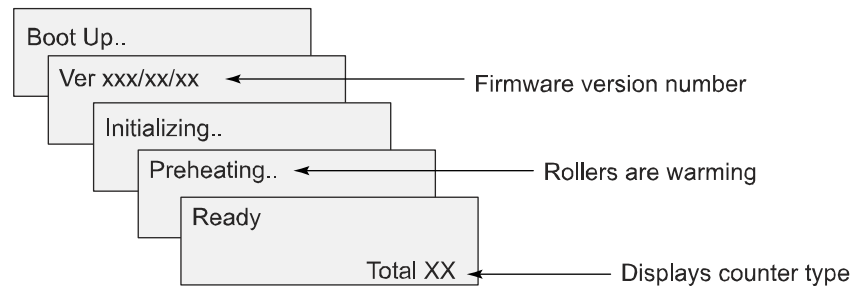

Prepare to print cards

Initialize the ink ribbon

Tips – Ink ribbon

- To avoid dirt and dust particles that might adhere to the ink ribbon during loading, move (initialize) the ink ribbon one or two panels each time the ink cartridge is removed from the printer.

- Press the RESET key on the control panel.
- The LCD display reads "Initialize OK?"
- Use the up and down arrow keys to select "2'nd Panel, OK?" or "Next Panel, OK?"
 - Press the ENTER key when "Initialize OK?" is displayed to initialize the printer without winding the ribbon.
 - Press the ENTER key when "2'nd panel, OK" is displayed and the printer winds the ribbon two panel sets.
 - Press the ENTER key when "Next Panel, OK?" is displayed and the printer winds the ribbon one panel set.

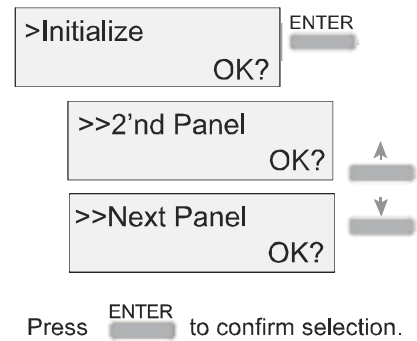
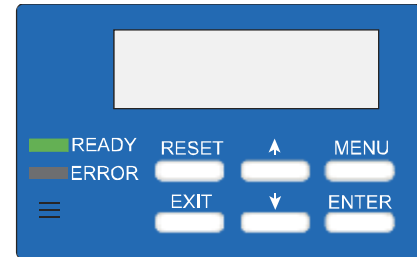

Set the retransfer film type

Tips – Retransfer film

- Set the retransfer film type when you set up the printer.
- If you change the type of film, set the type of retransfer film you are using.

- Press the MENU key until "Retransfer" is displayed.
- Press the ENTER key.
- "Media Type" is displayed.
- Use the up and down arrow keys to select Std (1000/roll). Selections of 250 and 750 are not available at this time.
- Press the ENTER key.
- Press EXIT twice to return to the "Ready" display.

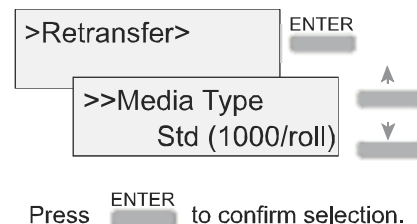
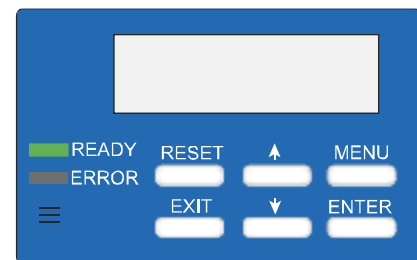

Initialize the retransfer film

Tips – Retransfer film

- To avoid dirt and dust particles that might adhere to the film during loading, (move) initialize the retransfer film one or two panels each time the film cartridge is removed from the printer.

- Press the RESET key on the control panel.
- The LCD display reads "Initialize OK?"
- Use the up and down arrow keys to select "2'nd Panel, OK?" or "Next Panel, OK?"
 - Press the ENTER key when "Initialize, OK?" is displayed to initialize the printer without winding the film.
 - Press the ENTER key when "2'nd panel, OK?" is displayed and the printer winds the retransfer film two panels.
 - Press the ENTER key when "Next Panel, OK?" is displayed and the printer winds the film one panel.

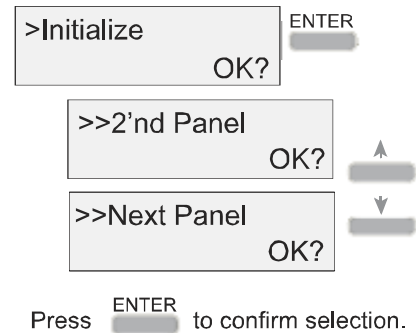
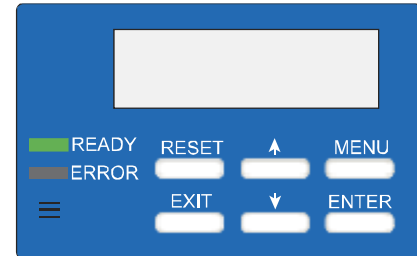

Initialize the patch or topcoat material (optional RL90 laminator only)

You must initialize the laminate material each time it is changed.



To initialize the laminate, press RESET/↑ and then the ENTER key on the laminator LCD panel.

Printing cards

Cards can be sent from ID software such as Datacard® ID Works® identification software. ID software handles the types of information used on cards.

If you do not have ID software, you can use another PC application to format the information to print on cards; however, most PC applications do not support magnetic stripe encoding or smart card programming. With any application, test the card design to verify the results.

The printer's LCD panel displays the following sequence when a card is sent to print:

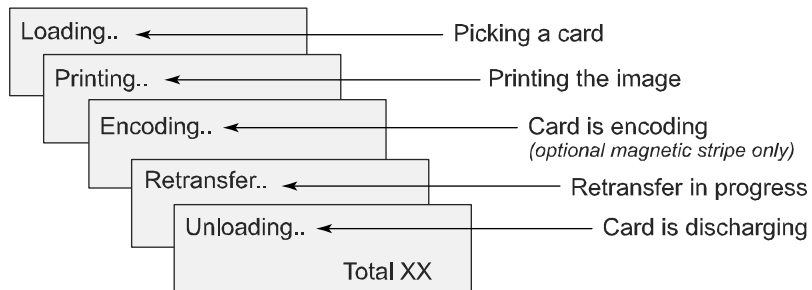

Print cards using ID software

- 1 Follow the instructions for the ID software to capture, format, and save the data for the card.
- 2 In the software, send cards to the printer (usually, use the Print button).
- 3 The printer driver receives data for each card, prepares the card for printing, and sends each card to the printer.



Print from a PC application

Tips – Printing

- The “Print” check box in the Print tab must be checked to print cards.
- During the printing operation, do not open the printer or optional laminator door.
- Do not open the card hopper when the printer LCD panel displays “Loading” through “Retransfer”.
- Do not turn the power off during the printing or laminating process.
- Do not unplug the printer or optional laminator during printing or laminating.
- Do not pull out the USB cable or the printer to laminator connection cable during printing or laminating.

- 1 Use the application's page setup feature to set the following:
 - Set paper or page size to CR80 card or 2.125" x 3.375"
 - Set the orientation for the card design – either portrait or landscape.
 - Set margins to zero for edge to edge printing.
- 2 Format and save the card information.
- 3 Select the Datacard RP90 Plus U1 printer from the Print dialog box. Datacard RP90 Plus U1 is the default name of the printer. Your printer may have a different name.
- 4 Click the Properties button to open the Printing Preferences dialog box. Use the Setup, Print, and Encode tabs to set printer properties.

Setup tab

Use the Setup tab to set the card orientation, number of copies, and whether to reverse the card. The Setup tab also displays the type of card, the type of ink ribbon in the printer, and the quantity of ink ribbon and retransfer film remaining.

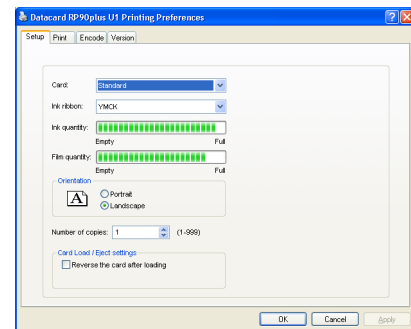

Print tab

Use the Print tab to set printing, printing one side or both sides, and rotate. The Print tab contains settings for using the color (YMC) and black (K) panels of the print ribbon. The tab also contains controls for color adjustment, setting up a look-up table, and specifying the print area for ribbon panels.

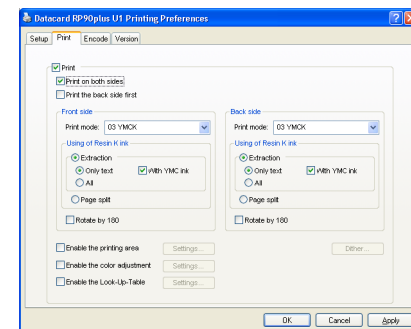

Encode tab

The Encode tab contains settings for using smart card (IC) and magnetic stripe encoding. You can also specify whether to rotate the card after an encoding step.

- 5 Print the card.

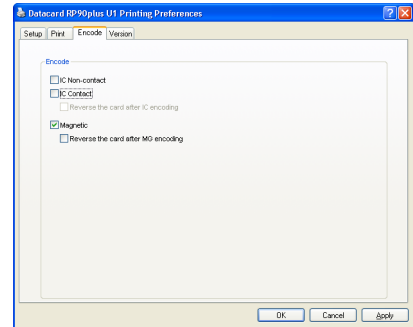

Viewing and changing printer settings

3

This section describes how to view and change printer and laminator settings. It describes:

- [“Printing Preferences” on page 22](#)
- [“Printing Properties” on page 23](#)
- [“Status Monitor” on page 24](#)
- [“Using the LCD menus” on page 32](#)
 - [“About the Printer LCD panel” on page 32](#)
 - [“Using the Printer LCD panel” on page 33](#)
 - [“About the Laminator LCD panel” on page 36](#)
 - [“Using the Laminator LCD panel” on page 37](#)

Printing Preferences

The Printing Preferences dialog box contains the Setup, Print, Encode, and Version tabs. To open Printing Preferences:

- 1 Choose Start from the Windows task bar.
- 2 Choose Settings and then Printers (and Faxes). The Printers (and Faxes) window opens.
- 3 Click once on the Datacard RP90 Plus printer icon to select it.
 - The driver must be installed for the printer icon to be present.
 - Datacard RP90plus U1 is the default name of the printer. The name of your printer might be different.
- 4 From the File menu, choose Preferences. The Printing Preferences dialog box opens.

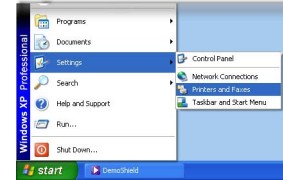

Setup tab

The Setup tab shows the type of card, the type of ink ribbon in the printer, and the quantity of ink ribbon and retransfer film remaining. You can specify the card orientation and number of copies (your ID software might specify these settings, which override the Setup tab). You can also specify whether to reverse the card.

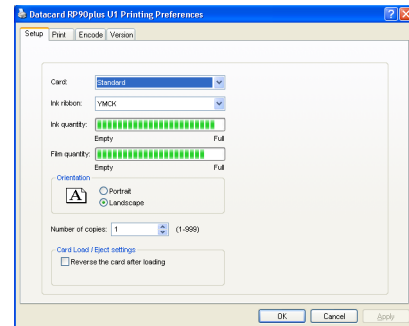

Print tab

The Print tab contains settings for using the color (YMC) and black (K) panels of the print ribbon. You can specify the whether to print on both sides and whether to rotate the image (your ID software might specify these settings, which override the Print tab). The tab also contains controls for color adjustment, setting up a look-up table, and dithering. Use the Printing area settings if using peel-off ribbon.

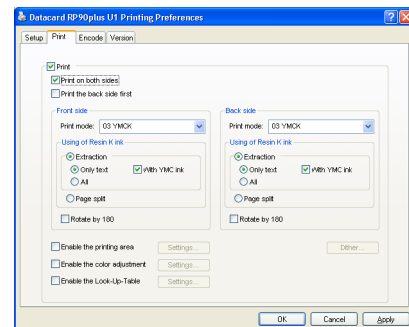

To print text, bar codes, or both using K ink on the side of a card using YMCK ink ribbon, choose Extraction>Only Text.

To print black areas on graphics with K ink ribbon, choose Extraction>All.

The look up table requires a file with a full set of 256 values (0-255) for each plane for Yellow, Magenta, Cyan, and Black. Each field can have a value from 0 through 255. Data should be ASCII numeric values, separated by a comma or line feed.

Encode tab

The Encode tab contains settings for using smart card (IC) and magnetic stripe encoding (your ID software might specify these settings, which override the Encode tab). You can also specify whether to rotate the card after an encoding step.

See “[Magnetic Stripe Encoding](#)” on page 73 for more information on encoding magnetic stripes.

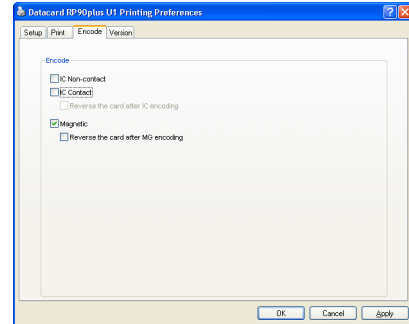

Version tab

The Version tab shows the build version of the printer driver. Your service provider might ask you for this information.

The version number has the format *[nnnn-xxxx-yy-zz]* where:

nnnn is the version of the printer driver

xxxx is the version of printer firmware

yy is the version of the config in the printer

zz is the version of the table in the printer

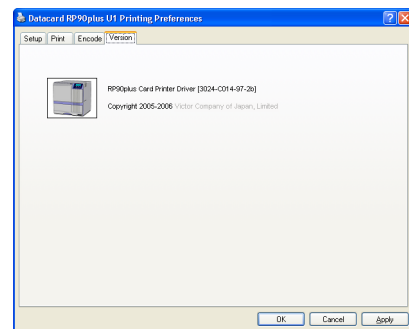

Printing Properties

The Printing Properties dialog box options are set up when the printer is installed or by your system administrator.

- 1 Choose Start from the Windows task bar.
- 2 Choose Settings and then Printers (and Faxes). The Printers (and Faxes) window opens.
- 3 Click once on the Datacard RP90 Plus U1 printer icon to select it.
 - The driver must be installed for the printer icon to be present.
 - Datacard RP90 Plus U1 is the default name of the printer. The name of your printer might be different.
- 4 From the File menu, choose Properties. The Properties window opens.
- 5 Use the tabs to set up Sharing, Ports, Color Management, Security, and Advanced options.
- 6 Choose OK to save and close, or choose Cancel to close without saving changes.

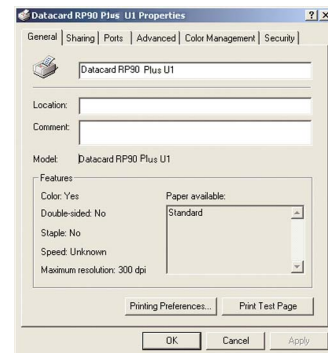

Status Monitor

Tips – Card cleaning roller

- Values are blank if the printer is disconnected or powered off.
- Graphics controls show all red if the printer is disconnected or powered off.
- Clicking on buttons displays the “No printer is found.” message if the printer is disconnected or powered off.

The Status Monitor can be installed when the driver is installed. The Status Monitor handles bidirectional communication between the printer and printer driver. You can use the Status Monitor or the printer LCD panel for many settings.

To open the Status Monitor window:

- 1 Begin with the printer powered on and attached to the PC.
- 2 From the Windows task bar, choose Start>Programs>RP90 Plus Status Monitor>RP90 Plus Status Monitor.
 - If an icon is installed on the desktop, click the icon to open the Status Monitor window.
- 3 The Status Monitor window opens.







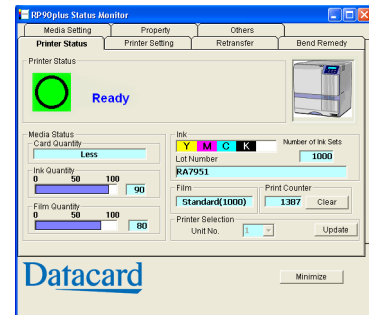

Status tab

The Status tab shows:

- The type of ink ribbon, the approximate percentage remaining, and the lot number.
- The type of retransfer (INTM) supply and the approximate percentage remaining.
- The resettable print count and a **Clear** button to set it to zero (0).
- The unit number. If more than one printer is installed, choose the printer to work with using the **Unit No.** list. Click the **Update** button to display information for the chosen printer.
- An estimate of the cards remaining in the card hopper. **Less** means:
 - 25 or fewer 0.76mm (0.030in) cards
 - 70 or fewer 0.25mm (0.010in) cards
- When the printer requires cleaning, the printer image changes to:



- The current state of the printer, such as ready. The icon changes with different states. See the table below.

Icon	Status	Icon Color	Meaning
	No Printer is found.	Yellow	The printer power is not switched on. or the host PC and printer are not connected properly by the USB cable.
	Ready	Green	The printer is ready and able to start card printing.
	Initializing	Yellow	The printer is initializing. After the printer is initialized, it goes into Ready state.
	Offline Mode	Yellow	The printer is in Setting mode or it is being cleaned. When the process ends, it goes into Ready state.
	Preheating	Yellow	The heat roller is heating. When it reaches the correct temperature, the printer goes into Ready state.
	Card Loading Card Transporting MG Encoding Retransfer Contact IC Encoding No-Contact IC Encoding Unloading Printing	Yellow	The printer is issuing cards. The operating status during card issuing is indicated. When the card is issued, the printer goes into Ready state.
	Power Saving	Yellow	The printer is in power save mode. To end Power Saving, press the RESET button on the printer and then press the ENTER button to initialize the printer.
	Error	Red	See “ Status monitor messages ” on page 28.

Printer Setting tab

The Printer Setting tab shows:

- Controls for viewing or changing print settings:
 - Resin K Print Level, which sets the K resin ink print density.
 - Level of Special Ink 1 and Level of Special Ink 2 which are not supported.
 - Resin K Print Mode which sets the K resin ink print quality. If Fine is selected, the print quality improves but the printing speed is slower.
 - Peel Off Wait Time which sets the time in seconds to wait until the retransfer film peels off from the card after retransfer. The default value is 0.
- Controls for viewing or changing magnetic stripe settings.

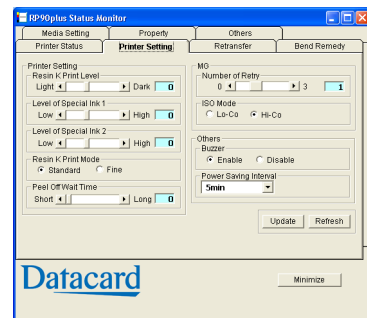

- Number of Retry, which sets the maximum number of retries when writing or reading magnetic stripe data fails. Default value is 1.
- ISO Mode, which sets the power used by the magnetic card encoder. The default is Hi-Co.
- A control to enable or disable the buzzer.
- A control to view or change the wait time before power saving.

Retransfer tab

The Retransfer tab shows:

- Two matrices for setting the retransfer speed and temperature. Click a square to choose the setting. On the printer, press the **Reset** button and then the **Enter** button to initialize the printer and make the new setting take effect.
- The card type, set on the Media Setting tab.
- The Refresh button which displays the current printer data.

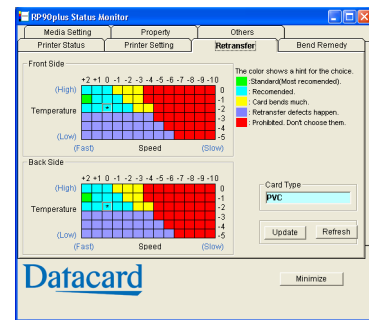

Tips for success

- The transfer power to the card gets stronger towards the upper right, but the card becomes more distorted due to the heat.
- Changing the retransfer temperature on one card side also affects the other side.
- The range of values changes with the Card Type.
- Make sample cards to verify settings before using new settings.

Bend Remedy tab

The Bend Remedy tab shows:

- A matrix for setting the bend remedy time and temperature. Click a square to choose the setting. On the printer, press the **Reset** button and then the **Enter** button to initialize the printer and make the new setting take effect.
- The card type, set on the Media Setting tab.

Tips for success

- Bend remedy is effective for single side printing. For double side printing, choose the **Off** button.
- When you change to Off, the printer goes into **Preheat** state for about 10 minutes while the roller temperature drops. Wait until the printer state Changes to **Ready**.
- The side where bend remedy is performed can become faded.
- Make sample cards to verify settings before using new settings.

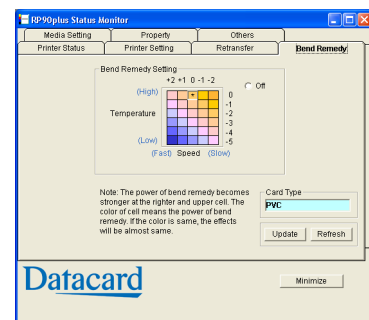

Media Setting tab

The Media Setting tab shows:

- The type of Ink ribbon in the printer, the lot number of the ribbon, and the number of panel sets included in the ribbon. The printer provides this information and it cannot be changed. If the printer cannot recognize the type of ink ribbon, one of the following reasons is displayed:

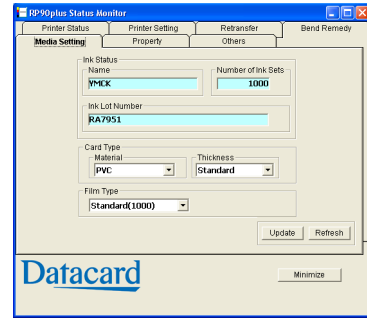

Display	Reasons for ink recognition error and the solutions
252: Invalid TAG Data	The data for the ink ribbon is incorrect. Replace the ink ribbon and try again.
253: Defective TAG	The printer did not recognize the print ribbon data. Replace the ink ribbon and try again.
254: No TAG	The printer could not read the print ribbon data. Make sure the ink ribbon has been loaded correctly. See “Load ink ribbon” on page 9.
255: Defective R/W	The printer is defective. The printer must be repaired.

- Settings to view or change the type and thickness of cards being used.
 - For Material, choose PET-G, PVC, or PET (0.25mm). The values for retransfer speed and temperature (on the [“Retransfer tab”](#)) change depending on the selected card type.
 - For Thickness, choose:
 - Standard for cards 0.76mm (0.030in) thick
 - Thin for cards 0.25mm (0.010in) thick
- A setting to view or change the type of Retransfer (INTM) film.

Tips for success

- Make sample cards to verify settings before using cards of a different thickness.
- Print on one side of thin cards. Do not print on both sides.

Property tab

The Property tab shows:

- The version of printer firmware, and firmware versions of any installed options such as magnetic stripe encoder or laminator. “????” means an option is not installed or connected.
- Configuration information for options installed.
- The unit number. (Use the LCD panel to set the unit number, described in [“Using the Printer LCD panel” on page 33.](#))

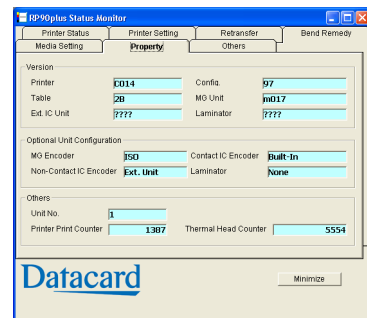

- The Print Count, which is the number of cards printed.
- The Thermal Head count, which is the number of panels printed by the printhead currently installed in the printer. (YMCK ink ribbon has four panels.)

Others tab

The Others tab shows:

- Controls for printing a test card. The printer will create one test card, using the internal test pattern.
- A control for saving a command log. Your service provider might ask you to save a command log as part of troubleshooting.
- Controls for selecting a firmware file and sending it to the printer. Only update printer firmware when your service provider recommends it.
- Version information for the status monitor.

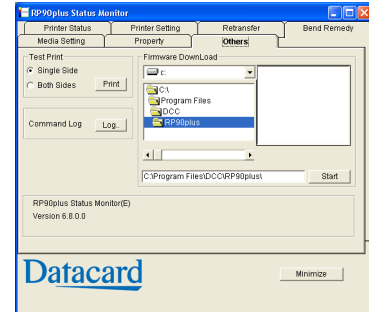

Status monitor messages

Message appear on the “[Status tab](#)” on [page 24](#).

Error Code	Displayed Message	Solution
	No Printer is found.	<ul style="list-style-type: none"> • Make sure that the host PC and the printers are connected properly with a USB cable. • Make sure that the printer is switched on.
0102D000	There is no card. Please supply cards.	<ol style="list-style-type: none"> 1 Load cards as described in “Load cards” on page 8. 2 Close or replace the card hopper securely.
0102D100	Printer door is opened. Please close the door and initialize the printer by pressing RESET and ENTER button.	<ol style="list-style-type: none"> 1 Close the printer door. 2 Press RESET and then ENTER to initialize the printer.
0102D600	Ink Ribbon Cassette or Retransfer Film Cassette is not set.	<ol style="list-style-type: none"> 1 Load the Ink Ribbon Cassette or Retransfer Film Cassette and then close the printer door. 2 Press RESET and then ENTER to initialize the printer.
0102D700	Cleaning Unit is not set.	<ol style="list-style-type: none"> 1 Install the Cleaning Unit and then close the card hopper. 2 Press RESET and then ENTER to initialize the printer.
01039000	Feed Jam happens. Please unset the card tray and remove the card after turning off the printer power.	<ol style="list-style-type: none"> 1 Switch off the printer power. 2 See “Hopper jam” on page 48 to remove the card. 3 Switch on the printer power.

01039100	Card Jam happens in the printer. Please open the printer door and remove the card after turning off the printer power.	<ol style="list-style-type: none"> 1 Switch off the printer power. 2 See “Turnover jam” on page 49 to remove the card. 3 Switch on the printer power.
01039200	Card Jam happens in the printer. Please open the printer door and remove the card after turning off the printer power.	<ol style="list-style-type: none"> 1 Switch off the printer power. 2 See “Retransfer section jam” on page 50 to remove the card. 3 Check that the card stacker is securely attached to the card stacker receptacle. 4 Switch on the printer power.
01039300	Card Jam happens in the printer. Please open the printer door and remove the card after turning off the printer power.	<ol style="list-style-type: none"> 1 Switch off the printer power. 2 See “Retransfer section jam” on page 50 to remove the card. 3 Switch on the printer power.
01039400	Card Jam happens in the printer. Please open the printer door and remove the card around the card outlet after turning off the printer power.	<ol style="list-style-type: none"> 1 Switch off the printer power. 2 Open the printer door and remove the card near the card discharge slot. 3 Switch on the printer power.
0103A000	Retransfer Film is broken.	<ol style="list-style-type: none"> 1 Repair the retransfer film as described in “Mending broken ink ribbon or retransfer film” on page 51. 2 Press RESET and then ENTER to initialize the printer one ribbon panel.
0103A100	Mark on Retransfer Film could not be detected. Please set Retransfer Film correctly.	<ol style="list-style-type: none"> 1 Make sure that the Retransfer Film is loaded correctly (see “Load retransfer film” on page 10). 2 Close the printer door and press RESET and then ENTER to initialize the printer.
0103B000	Ink Ribbon is broken.	<ol style="list-style-type: none"> 1 Repair the ink ribbon as described in “Mending broken ink ribbon or retransfer film” on page 51. 2 Press RESET and then ENTER to initialize the printer.
0103B100	Ink Ribbon cannot be controlled. Please set Ink Ribbon correctly.	<ol style="list-style-type: none"> 1 Make sure that the Ink Ribbon is loaded correctly (see “Load ink ribbon” on page 9). 2 Close the printer door and press RESET and then ENTER to initialize the printer.
0103BB00	Card Jam happens in External IC unit. Please remove the card in External IC unit.	<ol style="list-style-type: none"> 1 Switch off the printer power. 2 Remove the jammed card from the IC unit on the right side of the printer. 3 Switch on the printer power.
01044400 0104D800 0104FA00	Hardware failure happens in the printer unit. Please turn off and on the printer power to initialize the printer.	<ol style="list-style-type: none"> 1 Turn the printer power switch off and then on. 2 If the error happens again, call for service.

0104A900	MG encoder is not set correctly. Please turn off the printer power and set MG unit correctly.	<ol style="list-style-type: none"> 1 Turn the printer power switch off and then on. 2 If the error happens again, call for service.
0104AB00	Mechanical failure happens in the MG encoder. Please turn off and on the printer power to initialize the printer.	<ol style="list-style-type: none"> 1 Turn the printer power switch off and then on. 2 If the error happens again, call for service.
0104AC00	Hardware failure happens in the MG encoder. Please turn off and on the printer power to initialize the printer.	<ol style="list-style-type: none"> 1 Turn the printer power switch off and then on. 2 If the error happens again, call for service.
0104AF00	Communication error happens between printer and MG encoder. Please turn off and on the printer power to initialize the printer.	<ol style="list-style-type: none"> 1 Turn the printer power switch off and then on. 2 If the error happens again, call for service.
0104B900	External IC unit is not set correctly. Please turn off the printer power and set External IC unit correctly.	<ol style="list-style-type: none"> 1 Turn the printer power switch off and then on. 2 If the error happens again, call for service.
0104BA00	Dip switch setting in the external IC unit is not correct. Please turn off the printer power and correct Dip switch setting in External IC unit.	<ol style="list-style-type: none"> 1 Turn the printer power switch off and then on. 2 If the error happens again, call for service.
0104BE00	Communication error happens between printer and External IC unit. Please turn off the printer power and connect communication cable correctly.	<ol style="list-style-type: none"> 1 Switch off the printer power. 2 Connect the cable between the External IC unit and the printer securely. 3 Switch on the printer power. 4 If the error happens again, call for service.
0104BF00	Communication error happens between printer and laminator. Please turn off the printer power and connect communication cable correctly.	<ol style="list-style-type: none"> 1 Switch off the printer power AND laminator power. 2 Connect the cable between the laminator and the printer securely. 3 Switch on the printer and laminator power. See "Power on the printer" on page 15 and "Power on the laminator" on page 14. 4 If the error happens again, call for service.
0104C000	Hardware failure happens in the turnover unit. Please turn off and on the printer power to initialize the printer.	<ol style="list-style-type: none"> 1 Turn the printer power switch off and then on. 2 If the error happens again, contact you service provider.
0104C100	Hardware failure of Heater Cam happens. Please turn off and on the printer power to initialize the printer.	<ol style="list-style-type: none"> 1 Turn the printer power switch off and then on. 2 If the error happens again, call for service.
0104F000	The temperature of Retransfer Roller is too hot. Please turn off the printer power till it becomes cool enough.	<ol style="list-style-type: none"> 1 Switch off the printer power. 2 Wait about 10 minutes for the Retransfer Roller to cool down. 3 Switch on the printer power. 4 If the error happens again, call for service.

0104F100	Hardware failure of Retransfer Roller happens. Please turn off and on the printer power to initialize the printer.	<ol style="list-style-type: none"> 1 Turn the printer power switch off and then on. 2 If the error happens again, call for service.
0104AC00	Hardware failure happens in the MG encoder. Please turn off and on the printer power to initialize the printer.	<ol style="list-style-type: none"> 1 Turn the printer power switch off and then on. 2 If the error happens again, call for service.
0104F200	Hardware failure of Retransfer Roller Thermister happens. Please turn off and on the printer power to initialize the printer.	<ol style="list-style-type: none"> 1 Turn the printer power switch off and then on. 2 If the error happens again, call for service.
0104F300	The temperature of Bend Remedial Roller is too hot. Please turn off the printer power till it becomes cool enough.	<ol style="list-style-type: none"> 1 Switch off the printer power. 2 Wait about 10 minutes for the Bend Remedial Roller to cool down. 3 Switch on the printer power. 4 If the error happens again, call for service.
0104F400	Hardware failure of Bend Remedial Roller happens. Please turn off and on the printer power to initialize the printer.	<ol style="list-style-type: none"> 1 Turn the printer power switch off and then on. 2 If the error happens again, call for service.
0104F500	Bend Remedial Roller thermister is out of order. Please turn off and on the printer power to initialize the printer.	<ol style="list-style-type: none"> 1 Turn the printer power switch off and then on. 2 If the error happens again, call for service.
0104F600	The temperature in the printer is too cool. Please turn off the printer power till it becomes warm enough.	<ol style="list-style-type: none"> 1 Switch off the printer power. 2 Wait for the surrounding temperature to warm up. 3 Switch on the printer power. 4 If the error happens again, call for service.
0104F800	The temperature of Thermal Head is too hot. Please turn off the printer power till it becomes cool enough.	<ol style="list-style-type: none"> 1 Switch off the printer power. 2 Wait about 10 minutes for the Thermal head to cool down. 3 Switch on the printer power. 4 If the error happens again, call for service.
0105FB00	Download data to the printer is invalid. Please confirm the file is correct.	Check whether the downloaded file is correct.
0142A200	End of Retransfer Film, please replace the film with a new.	<ol style="list-style-type: none"> 1 Replace with a new roll of retransfer film. See "Load retransfer film" on page 10. 2 Press RESET and then ENTER to initialize the printer. 3 Initialize the new roll of film as described in "Initialize the retransfer film" on page 17.
0142B200	End of Ink Ribbon, please replace the ink with a new.	<ol style="list-style-type: none"> 1 Replace with a new roll of ink ribbon. See "Load ink ribbon" on page 9. 2 Press RESET and then ENTER to initialize the printer. 3 Initialize the new roll of ink ribbon as described in "Initialize the ink ribbon" on page 16.

Using the LCD menus

About the Printer LCD panel

The printer LCD panel has a 2-line display, six keys, a Ready light, Error light, and speaker.

The display background color changes according to the printer's function; the background is bright green during initialization, orange while processing a card, and red on printer error. These colors can be changed using the LCD panel.

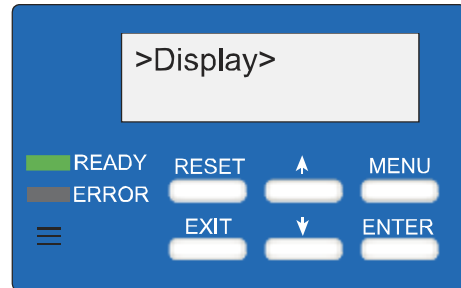

Ready LED (green)

Steady Green	The printer is ready and waiting to print cards.
Blinking	The printer is receiving data.
Off	The printer stopped due to error, initialization or preheat mode, or operator setting preferences.

Error LED (red)

On	The printer has a condition that requires service or the printer did not power on correctly. To correct the condition, press the RESET and then the ENTER key. If this does not correct the condition, power the printer off, and then back on before calling for service.
OFF	Normal status

Keys:

Reset	Initializes the printer after an error occurs.
Menu	Press MENU to access the printer settings. Continue to press the MENU key to access the settings in the order listed in "Using the Printer LCD panel" on page 33 .
Enter	Confirms the user selection.
Arrow Keys	Use the up and down arrow keys to select options within a menu selection.
Exit	Exits the current menu or menu selection and returns user to the previous menu selection.

LCD Display

Line one of the display shows the current printer or mode status. The > symbol following a menu selection indicates that there are subcategories listed within the selection. Use the up and down arrow keys to select these options.

Press the MENU key and "User Mode" is displayed on the LCD panel. The LCD panel changes to read "Display" within 0.5 seconds.

Press the ENTER key when "Display" is shown to access display settings which include the card counter, LCD contrast, and LCD background color.

Press the MENU key when "Ready" is displayed to access other printer settings.

Press the EXIT key at any time to exit the menu system and return to "Ready" status.

Speaker

Provides an electronic beep that indicates:

- An error has happened.
- Fewer than 20 cards remain in the card hopper.
- Confirms that settings have been saved.

The speaker function can be turned on or off using the LCD panel.

Using the Printer LCD panel

Many printer settings can be changed using the ["Status Monitor"](#) described on page 24.

Menu Display	Settings	Function
Display	Counter <ul style="list-style-type: none"> • Total • Head • Free 	Use the up and down arrow keys to select the card counter type: <ul style="list-style-type: none"> • Total is the default setting, and displays the number of cards printed. The Total counter cannot be reset. • Head displays the number of complete dye panels. The Head counter cannot be reset, however, it automatically resets itself when the print head is replaced. • The Free counter displays the number of cards that have printed. The Free counter can be reset by the user.
	Contrast 0	Set the LCD panel contrast using 7 gradations from -3 (low contrast) to +3 (high contrast). The default setting is 0.
	Back Color SKY BLUE	Choose from eight LCD background colors. Sky blue is the default color. Other selections are blue, light blue, green, bright green, yellow, purple, and pink.
Counter Reset	OK?	Press ENTER to reset the Free counter.
Cleaning	Rollers OK? Magnetic Stripe Head	Start the cleaning function to clean the card feed rollers and heated rollers, and to clean the magnetic head when using magnetic stripe cards. See "Cleaning the card feed rollers and heat roller" or "Cleaning the magnetic head" for the steps to follow.
Ink	Ink Type YMCK: 0 YMCKPO: 2 YMCKK: 4	Displays the type of ink ribbon that is loaded in the printer. Datacard supports YMCK and YMCKK ink ribbons. (The printer detects the type of ink ribbon; it cannot be set.) See your dealer regarding support for YMCKPO ink ribbon.
	Black level	Choose from seven gradations from -3 (lighter) to +5 (darker).

Menu Display	Settings	Function
	Black mode	Choose Standard or Fine. Change to Fine if thin lines or small black text is blurred (printing speed is slower).
	SP - Ink1 Level	Use SP - Ink1 and Ink2 levels to set the darkness level of special inks that will be available in the future.
	SP - Ink2 Level	See SP -Ink1 Level above.
Retransfer	Media type: 750 1000	Datacard retransfer ribbon is available in 1000 frames per roll.
	Temp Level	Set the retransfer roller temperature. Set from -3 (lower) to +2 (higher).
	Speed (front)	Set the retransfer speed for the front of the card. Set from -10 (slower) to +2 (faster). Initialize the retransfer film after making changes. See "Initialize the retransfer film" .
	Speed (back)	Set the retransfer speed for the back of the card. Set from -10 (slower) to +2 (faster). Initialize the retransfer film after making changes. See "Initialize the retransfer film" .
	MG Print (JIS)	Select ON or OFF.
Standby	Front Wait Back Wait	When printing both sides of a card and using an optional smart card (IC) unit, specifies whether to wait after the front side or the back side of the card.
Buzzer	ON or OFF	Use to turn the electronic beep sound ON or OFF. The sound can indicate an error, when fewer than 20 cards remain in the card hopper, or to confirm a menu selection.
Power Saving	OFF or up to 60 minutes	The printer enters power save mode after a specified period of inactivity. Choose from OFF or select from 5 to 60 minutes in 5 minute increments. "Sleeping" appears on the LCD display. To cancel power save mode, press RESET and then the ENTER key.
Bend Remedy	Temp Level	Choose from -5 (lower) to 0 (higher) or OFF to set the bend remedy roller temperature. See "Bend remedy" for more information.
	Speed	Choose from -2 (slower) to +2 (faster) to set the bend remedy speed. See "Bend remedy" for more information.
	Cooling time	Set the cooling time from 0 (None) to 15 seconds.
Card Thickness	Standard Thin	Set Standard for 0.030 inch (0.76mm) thick cards or Thin for 0.010 inch (0.25mm) thick cards.
MG ISO Type	ISO coercivity setting Lo-Co Hi-Co	Set coercivity for writing data to ISO magnetic stripe cards: Lo-Co: 238×10^2 [A/m] (300[Oe]) Hi-Co: 218×10^3 [A/m] (2750[Oe])

Menu Display	Settings	Function
IC Antenna Pos	None EXT. Unit Added on	Select from three settings: <ul style="list-style-type: none"> • None for no antenna. • EXT.Unit when a smart card antenna is used. • Added on when a contact smart card is used.
IC Contact Pos	None Built-in EXT. Unit	Select from three positions to stop the card in: <ul style="list-style-type: none"> • None for no contact. • Built-in when the built-in contacts are used. • EXT. Unit when an external smart card option is used.
Test Print	OK?	Press the ENTER key to print the default test pattern. Test Print can be used with or without a host PC.
Unit No	Choose from 1 to 7	Assign the unit number when more than one printer is connected to a PC. Each unit attached to a PC must have a unique number. After choosing the unit number, press the ENTER key and then the EXIT key. "Please, power off" is displayed on the LCD panel. Power the printer off and then back on.
Transport Mode	Set transport mode	Set the Transport Mode when moving or shipping the printer. Press the ENTER key to use the transport mode. "Please, power off" is displayed on the LCD panel. The transport mode is cancelled when the printer is powered back on.

About the Laminator LCD panel

When you power on the laminator, it begins initializing. The laminator searches for laminate and then starts preheating. The laminator is ready when the LCD display reads "Ready" and the Ready light is steady green.

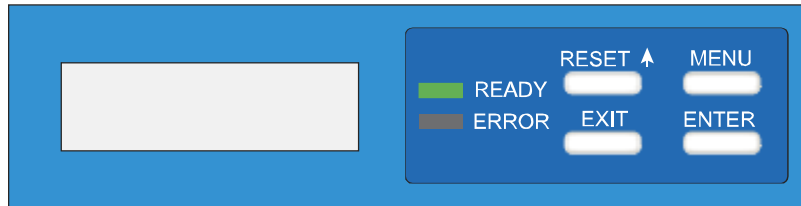

Ready LED (green)

Steady Green	The laminator is ready.
Blinking	The laminator busy.
Off	The laminator stopped because of an error, initialization or preheating is in progress, or the operator is using the LCD panel to set preferences.

Error LED (red)

On	The laminator may require service or did not power on correctly. To correct the condition, press the RESET/↑ and then the ENTER key. If this does not correct the condition, power the laminator off, and then back on before calling for service.
Off	Normal status

Keys:

MENU	Press MENU to access the laminator settings. Continue to press the MENU key to access the settings in the order listed on the next page.
ENTER	Confirms your selection.
EXIT	Exits the current selection and returns you to the previous menu selection. Press the EXIT key at any time to exit the menu system and return to "Ready" status.
RESET/↑	Initializes the laminator after an error occurs. Scrolls through available values when you change settings.

Using the Laminator LCD panel

All laminator settings must be made using the LCD panel.

LCD Display	Settings	Function
Mode	Single Pass	Default setting; laminates on one side only. Passes card without laminating.
Film	1-mil 0.6 mil overlay	1-mil is the default setting. Use it for patch film 1-mil thick. Use for patch film 0.6-mil thick. Use with topcoat with no positioning markings.
Film Position	-7 to +7	Adjusts the patch transfer position. Default setting is 0; the patch moves to the right with a positive value and to the left with a negative value.
Temp	Temperature, default 170°	Press the RESET/↑ key to set temperature from 130° C to 180° C in 5° increments. Press the ENTER key to confirm selection.
Speed	Lamination speed, default 5.5mm/sec	Press ENTER and use the RESET/↑ key to set lamination speed from 4mm/sec to 9mm/sec in 0.5mm/sec increments. The value that can be set may be limited by the temperature setting. Press the ENTER key to confirm selection.
Card Fan	Off, Low, Half, High, or Full	Press the RESET/↑ key to turn the card cooling fan Off (default), Low, Half, High, or Full. Press the ENTER key to confirm selection.
Cool Time	0 (default), 5, 7, or 10 seconds	Press the RESET/↑ key to select the amount of cooling time before laminating starts.
Power Save	Off, 10, 20, 30 (default), or 60 minutes	Lowers the heater temperature if no lamination has occurred in the set time period. Preheating automatically returns when a card enters the laminator.
LCD contrast	1 to 5	Press the RESET/↑ key to set the LCD display contrast from 1 to 5. The larger the number, the higher the contrast.
Cleaning	Without HR	Cleans the transport roller only.
	With HR	Cleans transport and heat rollers. The laminate cartridge must be removed to clean the heat roller. See “Cleaning the laminator” for more information.

Taking care of your printer

4

This chapter provides information to help you maintain the Datacard® RP90 Plus printer and the Datacard® RL90 card laminator for optimal performance. It describes:

Cleaning the printer

- [“Cleaning the card cleaning rollers” on page 40](#)
- [“Card feed roller” on page 40](#)
- [“Cleaning the card feed rollers and heat roller” on page 41](#)
- [“Cleaning the magnetic head” on page 42](#)
- [“Cleaning the thermal head” on page 43](#)
- [“Cleaning printer fan filters” on page 43](#)

Cleaning the laminator

- [“Run a laminator cleaning card” on page 44](#)
- [“Cleaning the laminator cartridge” on page 45](#)
- [“Laminator fan filter” on page 45](#)

Cleaning the printer

This section provides information on proper care and cleaning of the RP90 Plus printer. It also includes recommendations on how often to clean and replace components.

Tips – Card cleaning roller

- Wash the card cleaning rollers regularly, such as every time you change the ink ribbon.
- More frequent cleaning may be required under heavy use conditions. Clean rollers every 200 cards to improve print quality.
- Allow the card cleaning rollers to dry thoroughly before reinstalling them in the printer.
- Replace the card cleaning rollers annually.

Cleaning the card cleaning rollers

The card cleaning rollers are located inside the card hopper and clean lint and other debris from the cards before printing. The card cleaning rollers should be cleaned regularly, such as every time the ink ribbon or retransfer film is changed. To clean the rollers:

- 1 Open the card hopper.
- 2 Pull the card cleaning rollers out.
- 3 Wash the blue cleaning rollers with water. Rub rollers gently under running water. Do not use isopropanol or detergents to clean the rollers.
- 4 Allow the card cleaning rollers to dry thoroughly.
- 5 Reinstall the cleaning unit with the blue rollers facing up.
- 6 Close the card hopper.

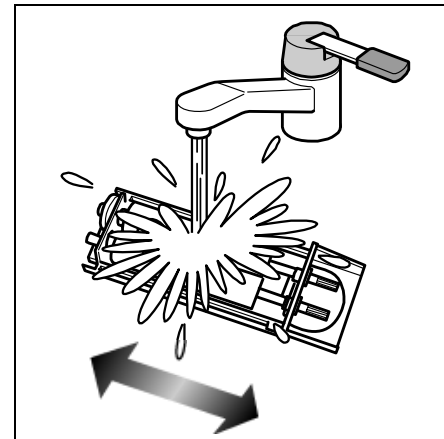
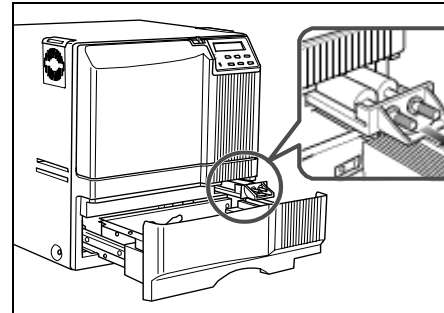

Card feed roller

The card feed rollers move the card through the printing process. To clean the card feed roller:

- 1 Open the card hopper and remove cards.
- 2 Slide the card bracket to the left until it locks.
- 3 Clean the card feed roller with a cotton swab dipped in ethanol.
- 4 Load cards as described in [“Load cards” on page 8](#).

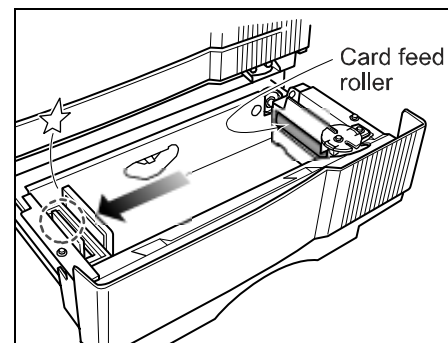

Cleaning the card feed rollers and heat roller

Tips – Cleaning card feed and heat rollers

- The heat roller cannot be cleaned while hot. Power the printer off and allow it to cool, or perform cleaning before the heat roller reaches operating temperature.
- Clean the card feed rollers and heat roller every 1,000 printed cards.
- Use the cleaning card one time only. Using a dirty cleaning card can cause damage to the rollers.

The heat roller provides the heat used during the retransfer process. The card feed rollers move the card inside the printer. See [“Printer roller layout” on page 47](#) to find the location of the rollers.

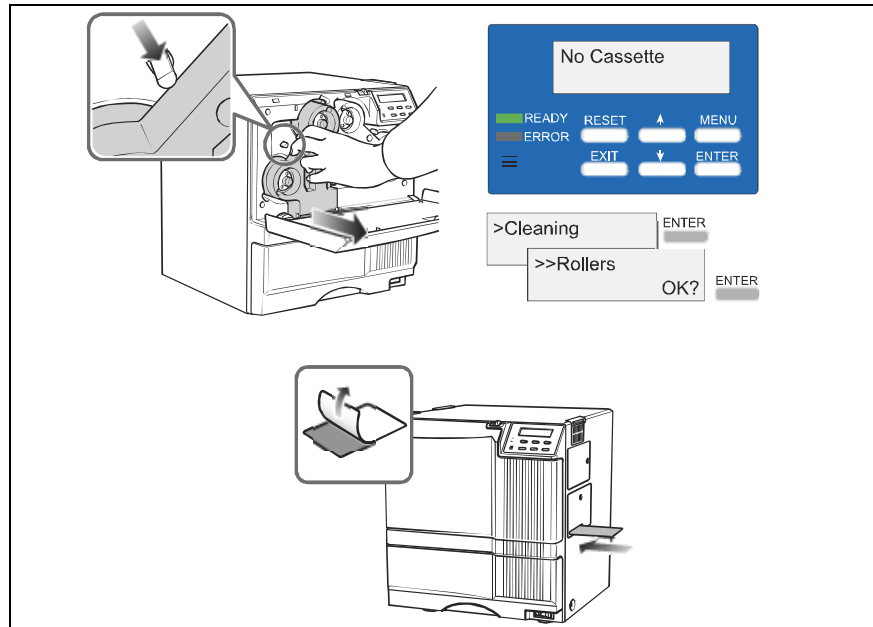

Begin with the printer (and optional laminator) powered off.

- 1 Move the RL90 laminator (if installed) away from the printer to avoid a card jam during the cleaning process.
- 2 Slide the door latch to the right and open the printer door.
- 3 Press the retransfer film cartridge eject button and remove the retransfer film cartridge.
- 4 Close the printer door.
- 5 Power on the printer. See [“Power on the printer” on page 15](#).
- 6 The "No Cassette" message is displayed on the LCD display.
- 7 Remove the protective paper from a cleaning card.
- 8 Press the MENU key until "Cleaning" is displayed.
- 9 Press the ENTER key.
- 10 "Rollers OK?" is displayed. Press the ENTER key.
- 11 Insert the cleaning card into the card slot located on the right side of the printer within 10 seconds. The card will be drawn into the printer by the rollers and cleaning will begin.
- 12 Turn the card over when it is discharged and repeat Step 11 to complete the cleaning process.
- 13 When the cleaning card is discharged, power off the printer, wait ten seconds, reinstall the retransfer film cartridge, and power back on.

Cleaning the magnetic head

When printing magnetic stripe cards, the magnetic head should be cleaned every 1,000 cards. If you are not using magnetic stripe cards, the magnetic head does not require cleaning.

Tips –Magnetic head cleaning card

- Replace the magnetic head cleaning card when it becomes dirty. Using a dirty magnetic head cleaning card can damage the magnetic head.

Begin with the printer (and optional laminator) powered off.

- 1 Move the RL90 laminator (if installed) away from the printer to avoid a card jam during the cleaning process.
- 2 Open the card hopper and remove cards.
- 3 Power on the printer. See [“Power on the printer” on page 15.](#)
- 4 Press the MENU key until "Cleaning" is displayed.
- 5 Press ENTER and use the up and down arrow keys to select "MG Head."
- 6 Place three or four drops of isopropanol on the stripe of the magnetic head cleaning card.
- 7 Place the magnetic head cleaning card in the card hopper in the correct orientation for the type of cards used. See [“Load cards” on page 8](#) for proper card orientation.
- 8 Close the card hopper and press the ENTER key on the LCD panel.
- 9 When the cleaning card is discharged, power off the printer, wait ten seconds, and power back on.

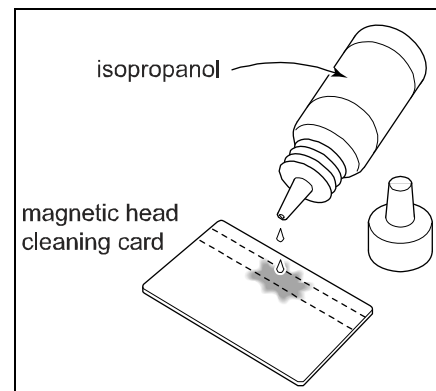
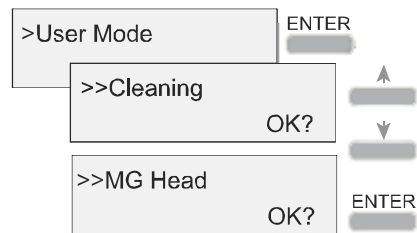
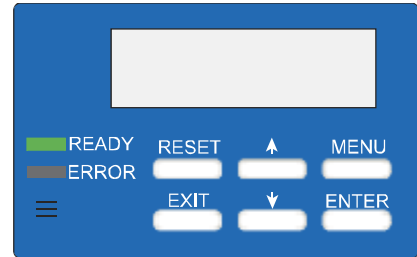

Cleaning the thermal head

Tips – Thermal head

- Do not use metal or other abrasive materials to clean the thermal head.
- The thermal head can be damaged by an electrostatic charge. Discharge yourself by touching the printer frame before cleaning the thermal head.

The thermal head assembly should be cleaned once every ten rolls of retransfer film.

Begin with the printer (and optional laminator) powered off.

- 1 Slide the door latch to the right and open the printer door.
- 2 Press the ink ribbon cartridge eject button and remove the ink ribbon cartridge.
- 3 Press the retransfer film cartridge eject button and remove the retransfer film cartridge.
- 4 Wipe the thermal head with a cotton swab dipped in ethanol.
- 5 Reinstall the ink ribbon cartridge and the retransfer film cartridge.
- 6 Close the printer door.

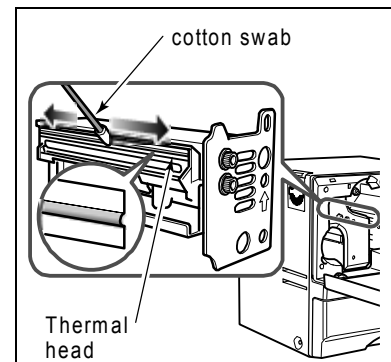
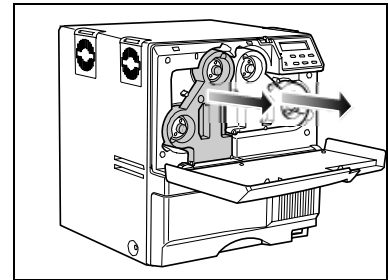

Cleaning printer fan filters

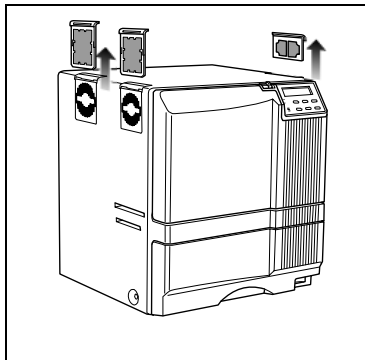

The printer has four fan filters to prevent airborne particles from entering the print area. Clean the filters regularly. Replace them when the foam begins to deteriorate.

- 1 Remove the external fan filters; remove two filters from the left side of the printer and one from the right side.
- 2 Remove the card hopper.
- 3 Remove the fan filter located on the upper surface of the card hopper housing by sliding the filter to the left and pulling down.
- 4 Clean the filters carefully using a vacuum cleaner. Hold the foam filter in place to prevent it from being pulled into the vacuum. Replace the foam filters into their frames if they have moved during cleaning.
- 5 Reinstall the filters into the printer.
- 6 Replace the card hopper.

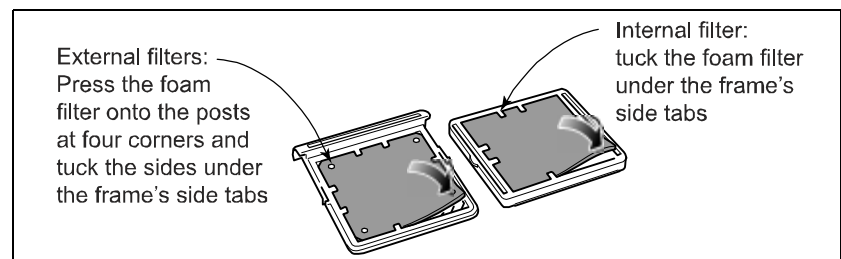
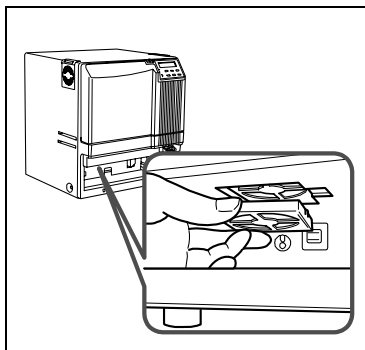

Cleaning the laminator

Most card jams are caused by dirty rollers. Clean the laminator at the same time that you clean the printer. If you are using the laminator as a stand-alone unit, clean the laminator every 1,000 cards.

Run a laminator cleaning card

Tips – Laminator cleaning card

- When the heat roller is at operating temperature, "HR is too hot" is displayed on the LCD display. Turn power OFF and allow unit to cool for approximately 30 minutes before starting the cleaning sequence.
- Use a cleaning card one time only. Using a dirty cleaning card can cause card jams.

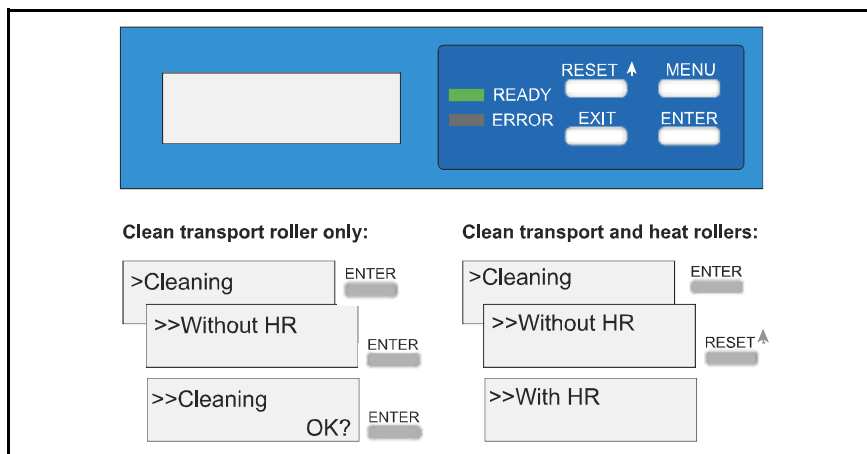

- 1 Press the MENU key on the laminator LCD panel until "Cleaning" is displayed.
- 2 To clean the transport roller only:
 - a Press the ENTER key and "Without HR" is displayed.
 - b Press the ENTER key and "Cleaning OK" is displayed.
 - c Press the ENTER key and cleaning starts.
- 3 To clean the transport roller and heat roller:
 - a Press RESET and then ENTER and "With HR" is displayed.
 - b Press ENTER and "Film removed?" is displayed.
 - c Remove the laminator cartridge, remove patch or topcoat material, replace the empty cartridge into the laminator, and close the laminator door.
 - d Press the ENTER key and "Cleaning OK?" is displayed.
 - e Remove the protective paper from the cleaning card and press the ENTER key.
 - f Slide the cleaning card into the card discharge slot. The card will be drawn into the laminator and will exit from the same slot when cleaning is complete.
- 4 Press the EXIT key twice to exit the cleaning menu.
- 5 Reload and initialize the material.

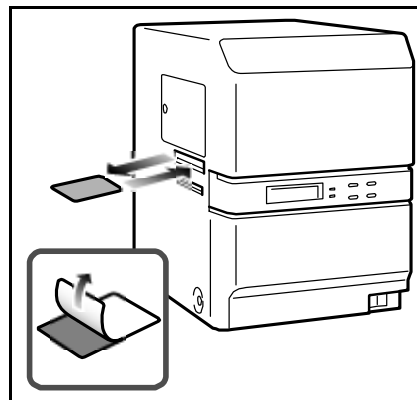

Cleaning the laminator cartridge

The laminator cartridge can collect debris and dust during lamination and supply loading. Clean the cartridge every 1,000 cards.

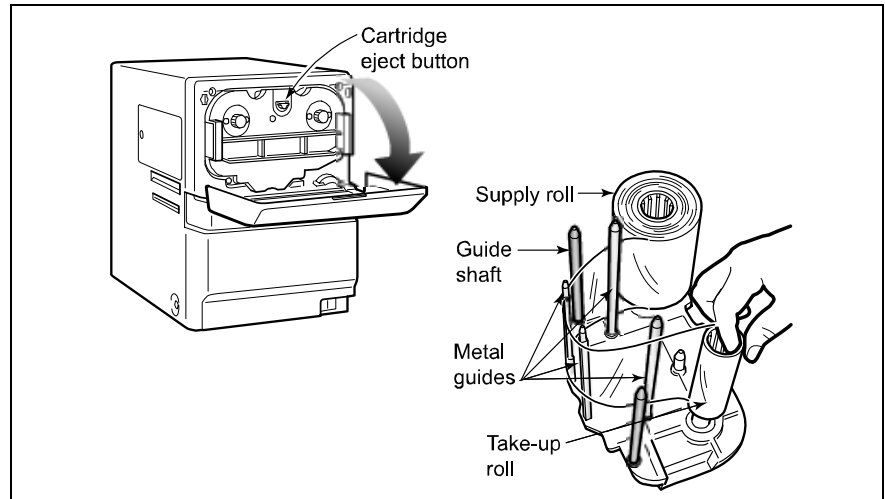

- 1 Open the laminator door by pulling the top of the door toward you.
- 2 Press the laminator cartridge eject button to remove the laminator cartridge.
- 3 Remove the supply and take-up spools if present.
- 4 Clean the two cartridge guide shafts and the four metal guides with a lint free cloth and ethanol.
- 5 Clean the laminator guide rails and the cartridge opening.
- 6 Replace the supply and take-up spools on the cartridge. See [“Load laminate” on page 11](#).
- 7 Replace the loaded laminator cartridge in the laminator until it clicks into position.
- 8 Close the laminator door.

Laminator fan filter

The laminator fan filter is designed to keep airborne particles from entering the unit. Clean the filter regularly and replace it when the foam begins to deteriorate.

- 1 Remove the filter from the back of the laminator by pulling the filter cover off.
- 2 Clean the filter carefully using a vacuum cleaner. Hold the foam filter in place to prevent it from being drawn into the vacuum.
- 3 Reinstall the filter.

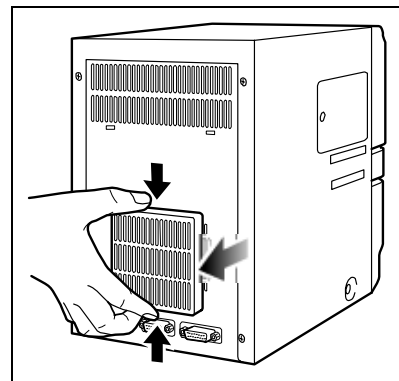

Messages and error recovery

5

This chapter provides information to help you respond to the printer and laminator messages and explains how to recover from an error. It describes:

- “Printer roller layout” on page 47
- “Printer error recovery” on page 48
- “Printer LCD messages” on page 54
- “Laminator error recovery” on page 58
- “Laminator LCD messages” on page 60

Printer roller layout

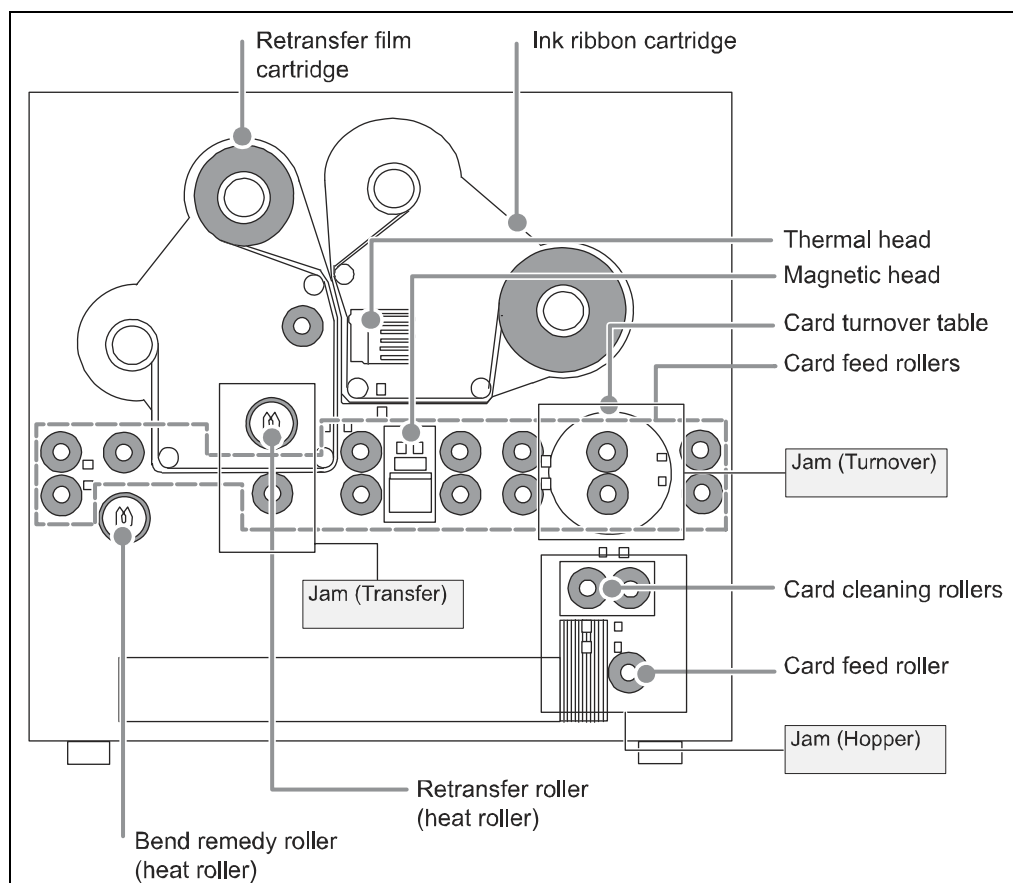

Printer error recovery

The printer's LCD panel background color changes to red when the printer has an error. The LCD panel displays text that describes the error.

Hopper jam

If a card jams in the card hopper section, "Jam (Hopper)" is displayed on the LCD panel. To remove the jammed card:

- 1 Pull the card hopper out and lift it slightly to remove it.
- 2 Remove the jammed cards:
 - If you can reach the jammed card, pull it out.
 - If you cannot reach the jammed card:
 - Pull the cleaning roller module out slightly.
 - Turn the knob on the right-hand side of the cleaning roller module clockwise to drop the jammed card. Remove the fallen card.
 - Push the cleaning roller module back into position.
- 3 Replace and close the card hopper.
- 4 Press the RESET and then the ENTER key to initialize the printer.

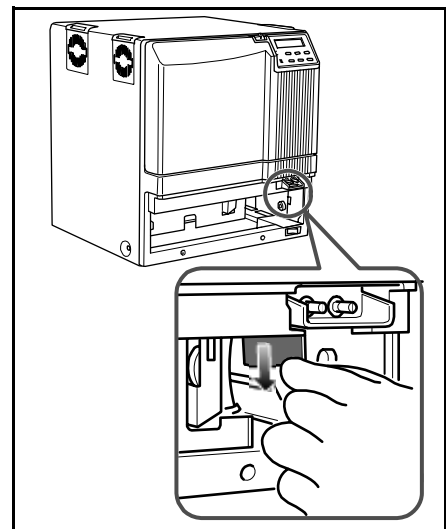
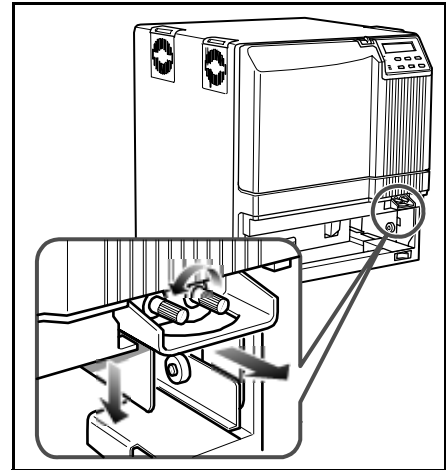
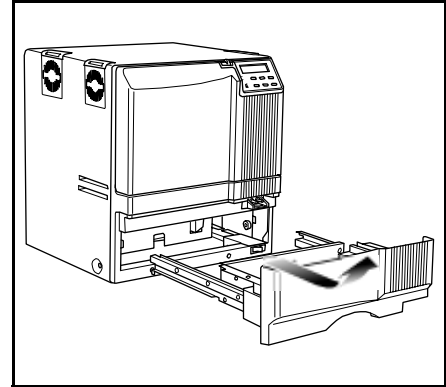

Turnover jam

If a card jams in the card turnover section, “Jam (Turnover)” is displayed on the LCD panel. To remove the jammed card:

Tips – Turnover jam

- Some internal parts may be hot. Wear a glove when rotating the turnover table.

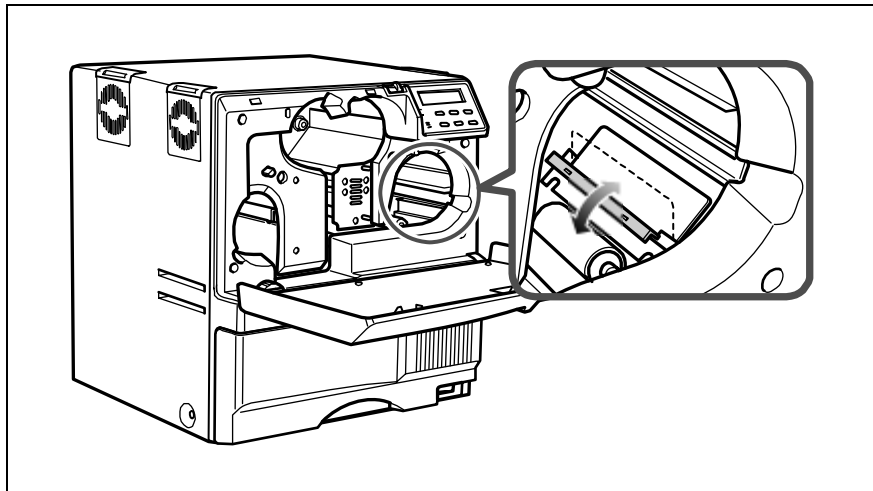

- 1 Slide the door latch to the right and open the printer door.
- 2 Press the ink ribbon cartridge eject button and remove the ink ribbon cartridge.
- 3 Remove the jammed card.
 - If you can reach the jammed card, pull it out.
 - If the jammed card is sticking out of the turnover table, push it back into the table, and rotate the table slowly until the card can be removed.
- 4 Replace the ink ribbon cartridge and initialize the ink ribbon as described in [“Initialize the ink ribbon”](#).

Retransfer section jam

If a card jams in the retransfer section, “Jam (Transfer)” is displayed on the LCD panel. To remove the jammed card:

Tips – Retransfer jam

- Some internal parts may be hot. Be careful when removing a jammed card.

- 1 Slide the door latch to the right and open the printer door.
- 2 Press the retransfer film cartridge eject button and remove the retransfer film cartridge.
- 3 Open the card hopper and remove the jog lever by pushing the retaining tab toward the front of the printer and lifting the jog lever.
- 4 Use the jog lever to turn the jog dial counterclockwise until the card can be removed.
- 5 Remove the card.
- 6 Replace the retransfer film cartridge and initialize the retransfer film as described in [“Initialize the retransfer film”](#).

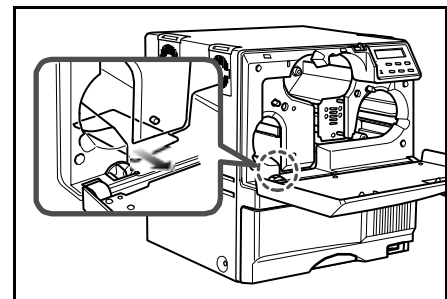
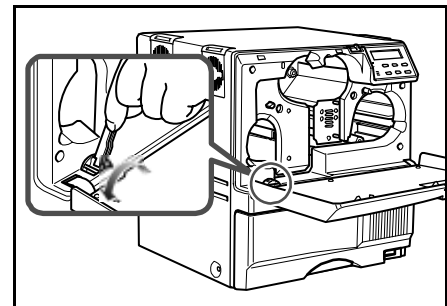
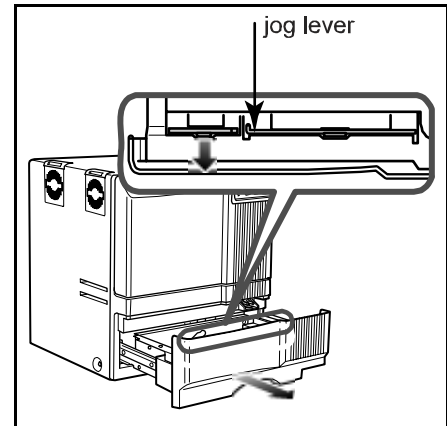

Mending broken ink ribbon or retransfer film

If the ink ribbon or retransfer film breaks, “Media Broken” is displayed on the LCD panel. Broken ink ribbon is shown in the following example; repairing broken retransfer film uses the same steps.

- 1 Slide the door latch to the right and open the printer door.
- 2 Remove the cartridge by pressing the cartridge eject button.
- 3 Trim the ends of the broken portions evenly.
- 4 Do not remove the used ink ribbon or film from the take-up spool.
- 5 Align the ends of the broken media evenly and apply tape to secure.
- 6 Turn the take-up spool clockwise until the mended portion is wound onto the spool two or three turns.
- 7 Reinstall the cartridge into the printer until it clicks into position.
- 8 Close printer door.
- 9 Initialize the ribbon or film as described in [“Initialize the ink ribbon”](#) or [“Initialize the retransfer film”](#).

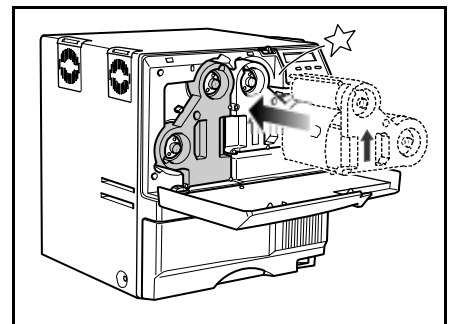
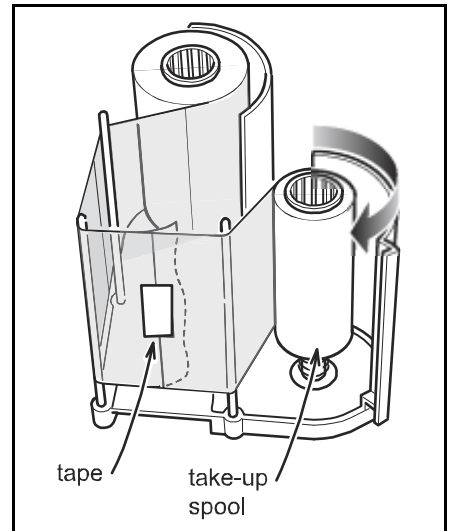
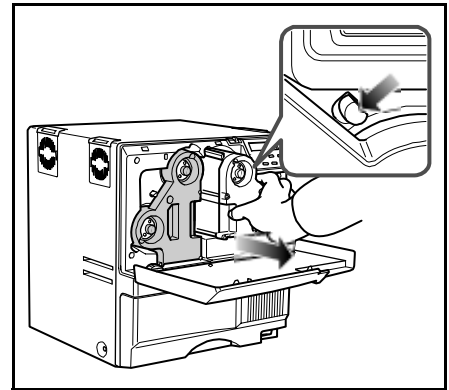

Bend remedy

Single-sided printing can cause the card to warp depending on the type of cards you use. Use the bend remedy Temp Level settings to correct the condition and use the Speed settings to fine tune the adjustment.

Bend remedy printer settings

You can also change the printer setting using the Status Monitor. See "[Bend Remedy tab](#)" on page 26.

Tips –Bend Remedy

- You must initialize the printer by pressing the RESET and then the ENTER key. Settings will not be saved if the printer is not initialized.
- Double-sided printing with the Temp Level set to a high temperature can cause severe warping. Set the Temp Level to OFF when printing on both sides of the card.
- Allow sufficient time for the bend remedy roller to cool after decreasing the temperature setting.

- Press the printer MENU key until "Bend Remedy" is displayed.
- Press the ENTER key. Choose from three bend remedy settings. Use the up and down arrow keys to select "Temp Level", "Speed", or "Cooling Time".

a Temp Level

Use the up and down arrow keys to set the bend remedy roller temperature. There are seven settings: off and -5 to 0. The higher the value, the higher the temperature. Press the ENTER key to confirm the value.

b Speed

Use the up and down arrow keys to set the bend remedy roller speed. There are five settings from -2 to +2; the higher the value, the faster the speed. Press the ENTER key to confirm the value.

c Cooling Time

Set the cooling time from zero to 15 seconds using the up and down arrow keys. Press the ENTER key to confirm the value.

- Press the RESET and then the ENTER key to initialize the printer.

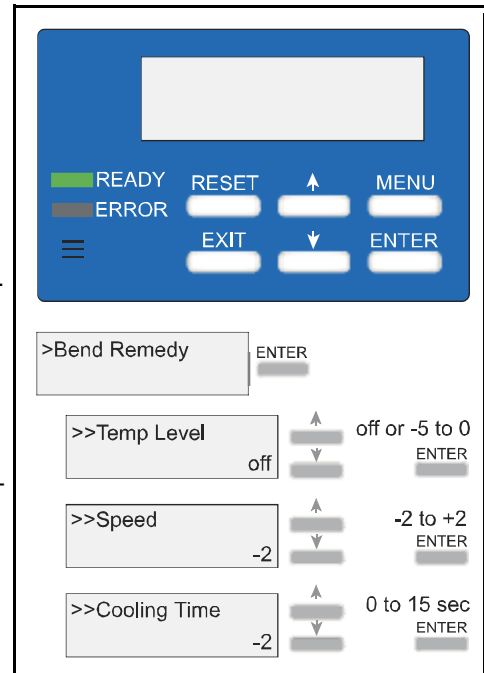

Bend remedy laminator settings

When the laminated card warps concave, the printer bend remedy settings should be effective in correcting the problem. See [“Bend remedy printer settings”](#) on the previous page.

If the laminated card warps convex, set the printer Bend Remedy> Temp Level to Off and set the laminator’s Card Fan to one of five settings.

Set the printer Bend Remedy>Temp Level to Off when laminating cards that have been printed on both sides.

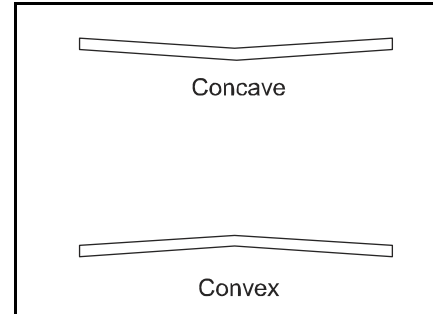

To set the laminator Card Fan:

- 1 Press the MENU key on the laminator LCD display until “Card Fan” is displayed.

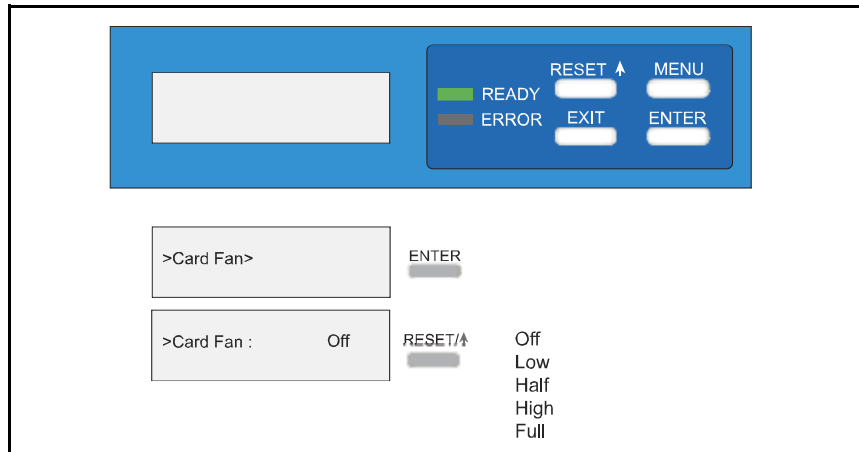

- 2 Press the ENTER key.
- 3 Press the RESET/↑ key to select from five settings: Off, Low, Half, High, or Full. You may need to experiment with this setting to obtain satisfactory results.
- 4 Press the ENTER key to confirm the setting.

Printer LCD messages

LCD Message	Possible Cause	Solution
Please, Power Off	The power must be turned off to initialize the printer.	Turn the power switch off and then on again.
Please Remove Media Cassette	Cleaning cannot start when the retransfer film cartridge is in the printer.	<ol style="list-style-type: none"> 1 Remove the retransfer film cartridge. 2 Press RESET and then ENTER to initialize the printer. 3 Start the cleaning cycle again.
HR is too hot	Cleaning cannot start because the temperature of the heat roller is too high.	<ol style="list-style-type: none"> 1 Power off the printer and allow the heat roller to cool for about 20 minutes. 2 Power on the printer and start cleaning again. Make sure that the retransfer film cartridge has been removed. 3 See “Cleaning the card feed rollers and heat roller” on page 41 for instructions on how to clean the card feed and heat rollers. 4 Contact your service provider if “HR is too hot” appears on the LCD panel and you are not cleaning the printer.
Jam (Hopper)	There is a card jam in the hopper section.	<ol style="list-style-type: none"> 1 Remove jammed card from the card hopper. 2 Press RESET, and then ENTER to initialize the printer. 3 See “Hopper jam” on page 48.
Jam (Turnover)	There is a card jam in the turnover section.	<ol style="list-style-type: none"> 1 Remove jammed card from the turnover section. 2 Press RESET, and then ENTER to initialize the printer. 3 See “Turnover jam” on page 49.
Jam (MG)	There is a card jam in the magnetic stripe encode section.	<ol style="list-style-type: none"> 1 Press RESET, and then ENTER to initialize the printer. If no card is discharged, remove the card from the encode section. 2 Press RESET, and then ENTER to initialize the printer.
Jam (Transfer)	There is a card jam in the retransfer section.	<ol style="list-style-type: none"> 1 Remove the jammed card from the retransfer section. 2 Press RESET, and then ENTER to initialize the printer. 3 See “Retransfer section jam” on page 50.
Jam (Discharge)	There is a card jam in the card discharge section.	<ol style="list-style-type: none"> 1 Press RESET, and then ENTER to initialize the printer. 2 Remove the jammed card from the retransfer section. 3 Check that the card stacker is securely attached to the stacker receptacle. An incorrectly mounted card stacker can cause discharge jams.

LCD Message	Possible Cause	Solution
Media Broken	The retransfer film is broken.	<ol style="list-style-type: none"> 1 Repair the retransfer film as described in “Mending broken ink ribbon or retransfer film” on page 51. 2 Press RESET, and then ENTER to initialize the printer one ribbon panel.
Media Search	The printer is searching for the retransfer film.	<ol style="list-style-type: none"> 1 Press RESET, and then ENTER to reset the retransfer film. 2 Call for service if the problem persists.
Media Run Out	The retransfer film has run out.	<ol style="list-style-type: none"> 1 Replace with new roll of retransfer film. 2 Press RESET, and then ENTER to initialize the printer. 3 Initialize the new roll of film as described in “Initialize the retransfer film”.
Ink Broken	The ink ribbon is broken.	<ol style="list-style-type: none"> 1 Repair the ink ribbon as described in “Mending broken ink ribbon or retransfer film” on page 51. 2 Press RESET, and then ENTER to initialize the printer.
Ink Search	The printer is searching for the ink ribbon.	<ol style="list-style-type: none"> 1 Press RESET, and then ENTER to reset the ink ribbon. 2 Call for service if the problem persists.
Ink Run Out	The ink ribbon has run out.	<ol style="list-style-type: none"> 1 Replace with a new roll of ink ribbon. 2 Press RESET, and then ENTER to initialize the printer. 3 Initialize the new ribbon as described in “Initialize the ink ribbon”.
Turn Over Unit	The card turnover device has malfunctioned.	Press RESET, and then ENTER to initialize the printer. Call for service if the problem persists.
Heater Cam	Heat roller operation error.	<ol style="list-style-type: none"> 1 Press RESET, and then ENTER to initialize the printer. 2 Call for service if the problem persists.
No Card	<ol style="list-style-type: none"> 1 There are no cards in the card hopper. 2 The card hopper is open or has been removed. 	<ol style="list-style-type: none"> 1 Load cards as described in “Load cards”. 2 Close or replace the card hopper securely.
Door Open	The printer door is open.	<ol style="list-style-type: none"> 1 Close the printer door. 2 Press RESET, and then ENTER to initialize the printer.
No Cleaning Ro.	The cleaning rollers are missing.	<ol style="list-style-type: none"> 1 Reinstall the cleaning rollers. 2 Press RESET, and then ENTER to initialize the printer. 3 See “Cleaning the card cleaning rollers” for more information.

LCD Message	Possible Cause	Solution
No Cassette	The ink ribbon or retransfer film cartridge is not installed.	<ol style="list-style-type: none"> 1 Install the cartridge(s) in printer. 2 Initialize the ink ribbon as described in “Initialize the ink ribbon”. 3 Initialize the retransfer film as described in “Initialize the retransfer film”.
Hardware	There is a hardware error.	Turn the power switch off and then on again. Call for service if the problem persists.
TR Overheat	The retransfer roller is too hot.	Turn the power switch off and then on again. Call for service if the problem persists.
TR Broken	The retransfer roller is not working.	Turn the power switch off and then on again. Call for service if the problem persists.
TR Sensor Broken	The retransfer roller thermistor is not working.	Turn the power switch off and then on again. Call for service if the problem persists.
RR Overheat	The bend remedy roller is too hot.	Turn the power switch off and then on again. Call for service if the problem persists.
RR Broken	The bend remedy roller is not working.	Turn the power switch off and then on again. Call for service if the problem persists.
RR Sensor Broken	The bend remedy roller thermistor is not working.	Turn the power switch off and then on again. Call for service if the problem persists.
Overcool	It is too cold for the printer to operate.	The temperature in the printer area is too low. Use at the recommended operating environment temperature as described in “Operating environment” .
Head Overheat	The thermal head is overheated.	Turn the power switch off and allow the printer to cool for approximately 10 minutes before turning power back on.
EEPROM Broken	EEPROM malfunction	Turn the power switch off and then on again. Call for service if the problem persists.
MG Unconnected	Magnetic stripe module connection error	Turn the power switch off and then on again. Call for service if the problem persists.
MG Mechanical	Magnetic stripe mechanical error	Turn the power switch off and then on again. Call for service if the problem persists.
MG Hardware	Magnetic stripe hardware error	Turn the power switch off and then on again. Call for service if the problem persists.
MG Write	Magnetic stripe writing error	<ol style="list-style-type: none"> 1 Check the orientation of magnetic stripe cards in the card hopper as described in “Load cards”. 2 Press RESET, and then ENTER to initialize the printer.

LCD Message	Possible Cause	Solution
EXT Unconnected	An external device, such as the optional laminator, is not working.	<ol style="list-style-type: none"> 1 Check that the laminator's power switch is on. 2 Make sure that the cable connecting the laminator to the printer is plugged in securely. 3 Turn the printer and optional laminator power switches off and then on again. 4 Call for service if the problem persists.
MG Read	Magnetic card reading error.	<ol style="list-style-type: none"> 1 Check the type and orientation of magnetic cards in the card hopper as described in "Load cards". 2 Press RESET, and then ENTER to initialize the printer.
MG Communicate	Magnetic stripe module communication error.	Turn the printer's power switch off and then on again. Press RESET, and then ENTER to initialize the printer.
EXT SW Setting	External device switch setting error.	Turn the printer's power switch off and then on again. Press RESET, and then ENTER to initialize the printer.
EXT Jam	External retransfer unit jam error.	<ol style="list-style-type: none"> 1 Press RESET, and then ENTER. 2 Remove cards if they are not discharged as described in "Retransfer section jam". 3 Press RESET, and then ENTER to initialize the printer.
EXT Communicate	External unit communications error.	Turn the printer's power switch off and then on again.
EXT 2 Communicate	The laminator communication is lost.	<ol style="list-style-type: none"> 4 REQUIRED: Power off the printer and laminator. 5 Make sure that the cable connecting the laminator to the printer is plugged in securely. 6 Turn the printer's power switch off and then on again.

Laminator error recovery

The laminator LCD panel displays the error.

Card jam

The laminator LCD panel displays the location of the card jam: Card Jam (In), Card Jam (Middle), or Card Jam (Out). Use the following steps to remove card jams.

Tips – Laminator card jam

- Make sure that the card stacker is not blocking the card discharge slot.
- The area around the heat roller is very hot. Be careful when removing a jammed card.

- 1 Open the laminator door by pulling the top of the door toward you.
- 2 Turn the take-up knob clockwise to remove slack in the laminator material.
- 3 Press the laminator cartridge eject button and remove the laminator cartridge. The cartridge may be difficult to remove; pull firmly, but do not force. If cartridge cannot be removed, call for service.
- 4 Use a coin to turn the jog dial, which will move the card. The jog dial can be turned clockwise or counterclockwise depending on the location of the card.
- 5 Remove the jammed card. The area around the heat roller is very hot. Be careful when removing a jammed card.

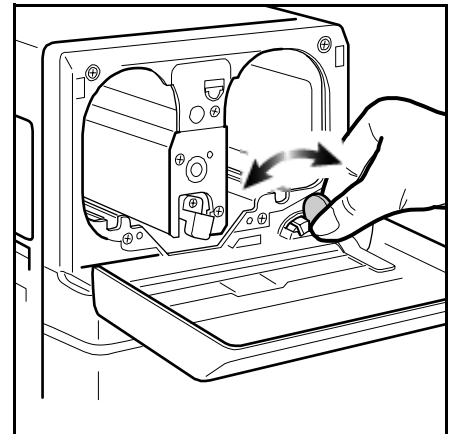
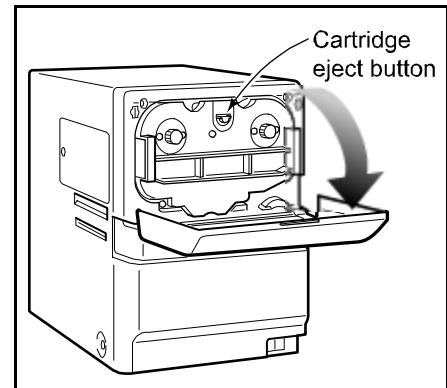

- 6 Inspect the cartridge:
 - If the material on the cartridge is in one piece:
 - Turn the cartridge take-up knob counter-clockwise until all damaged material is wound neatly on the take-up spool.
 - If the material is split or broken:
 - Trim the ends of the broken portions evenly.
 - Align the end of the supply material with the take-up spool and apply tape to secure.
 - Turn the material onto the take-up spool until the mended portion is wound two or three turns.
- 7 Replace the loaded laminator cartridge in the printer until it clicks into position.
- 8 Close the printer door.
- 9 Initialize the patch or topcoat material by pressing the laminator's RESET/↑ and then the ENTER key.

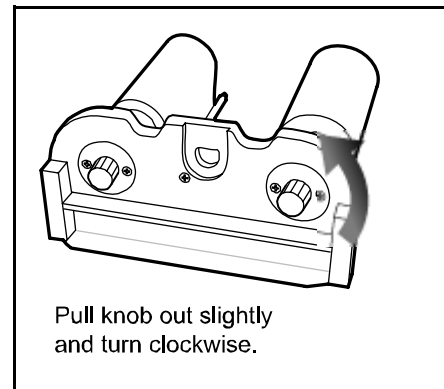
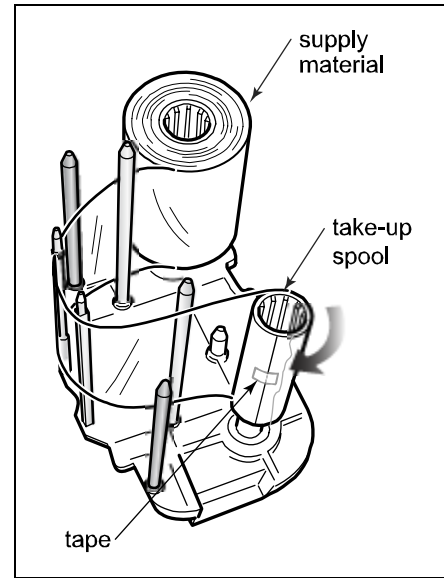

Laminator LCD messages

LCD Message	Possible Cause	Solution
Please Power OFF	To initialize this unit, the power must be switched off once.	Turn the laminator's power switch off, and then back on to initialize the laminator.
Please Reset	Displayed when Reset is necessary after changing the settings.	Press the RESET/↑ and then the ENTER key to initialize the laminator.
Please check inside	The power was switched off during lamination.	Remove the laminator cartridge and check for a card inside the machine. If there is a card in the machine, remove it. Press the RESET/↑ and then the ENTER key to initialize the laminator.
Card Jam (in)	There is a card jam in the entrance area.	Check that the laminator is properly connected to the printer as described in "Optional laminator connection" . See "Card jam" to clear the jam.
Card Jam (middle)	There is a card jam in the center of the card path.	The laminating temperature is too high or the speed is too slow. Set the temperature or speed as described in "Using the Laminator LCD panel" . See "Card jam" to clear the jam.
Card Jam (out)	There is a card jam in the card discharge area.	The laminating temperature is too high or the speed is too slow. See "Card jam" to clear the jam.
Film search	The laminator is searching for laminate material.	Check that the laminating film is correctly loaded as described in "Load laminate" . Press the RESET/↑ and then the ENTER key to initialize the laminating material.
Film run out	The end of the roll mark has been detected.	Replace the laminating material as described in "Load laminate" . Press the RESET/↑ and then the ENTER key to initialize the laminator.
No Cassette	The laminator cartridge is not installed.	Install the laminator cartridge as described in "Load laminate" . Press the RESET/↑ and then the ENTER key to initialize the laminator.
Overcool	The area surrounding the laminator is too cold.	See "Operating environment" for location guidelines.
HR is too hot!	The heat roller is too hot for the cleaning operation.	Turn the power switch off and allow the roller to cool before attempting to clean it. See "Cleaning the laminator" to clean the heat roller.
HR Cam	Heater Cam error.	Turn the power switch off, and then back on. Contact your service provider if this does not correct the condition.

LCD Message	Possible Cause	Solution
Heater Err	The heater temperature does not increase.	Check that the voltage inlet switch, located on the back of the laminator, is in the proper position for the input voltage. Contact your service provider if this does not correct the condition.
HR Overheat	Heat roller temperature is too high.	Turn the unit off and contact your service provider before powering back on.
Temp Sensor	The heat roller temperature sensor is not working.	Turn the unit off and contact your service provider before powering back on.
Memory Err	There is an internal memory error.	Turn the unit off and contact your service provider before powering back on.
Set Temp Err	There is an error with the heat temperature setting.	Turn the unit off and contact your service provider before powering back on.
R. Encoder Err	Rotary encoder error.	Turn the unit off and contact your service provider before powering back on.
Overheat	The temperature inside the unit is too high.	Turn the unit off and contact your service provider before powering back on.
PRT. Communicate	Communication error with the printer.	Check that the laminator cable is connected securely to the printer. Turn the printer and laminator off, and then back on to recycle the power.
Film Exchanged?	The patch or topcoat material was changed while the laminator was turned off.	Press the RESET/↑ and then the ENTER key to initialize the patch or topcoat material.

Supplies

6

This section outlines the recommended supplies to use with the Datacard® RP90 Plus card printer and the Datacard® RL90 card laminator.

- [“Ink ribbon, retransfer film, and laminator material” on page 64](#)
- [“Cards” on page 64](#)
- [“Cleaning supplies” on page 65](#)

Ink ribbon, retransfer film, and laminator material

Ink ribbon

Color print ribbons are designed for full-color card printing. The ribbons use the following color panels: Y=yellow, M=magenta, C=cyan/blue, and K=black.

The following ink ribbons are available:

YMCK 568971-001 (Prints up to 1,000 cards per roll.)

YMCKK 568971-002 (Prints up to 750 cards per roll.) Use when printing two-sided cards; full color on one side and black only on the other side.

Retransfer film

The following retransfer films are available:

564356-003 (Prints up to 1,000 single-sided cards.)

568971-003 (Prints up to 1,000 single-sided cards.)

Laminator material

Successful laminating depends on the type of card used and its construction. If you are interested in applying topcoat or patch on PVC cards, contact your dealer for guidance. Datacard® provides two types of materials for use in laminators:

- Topcoat, which is a continuous film.
- Patch, which has die-cut patches sized to fit on a card.

The RL90 laminator can apply any of the following types of laminator supply materials:

Patch material		Topcoat material	
0.6 mil clear patch	565394-002	clear topcoat	565394-003
1 mil clear patch	565394-001		

You might use custom materials similar to those listed above.

Cards

Card success depends on the manufacturer and card construction. This section describes specifications and quality guidelines for card stock to use with the RP90 Plus printer and the RL90 laminator. For best results, use high-quality card stock that meets the specifications and recommendations described in this section.

Use cards that conform to the following specifications:

- ISO/IEC 7810 Type ID1
- ISO/IEC 7811-2 Magnetic stripe (optional)
- ISO/IEC 7816 Smart card (optional)

Contact your service provider before using a preprinted magnetic stripe card or smart card. Dark color preprinted cards can cause positioning errors during encoding.

Card size

Use CR-80 size cards with the following nominal dimensions:

Length	3.375 inches	85.60 mm
Width	2.125 inches	53.98 mm
Thickness	0.010 or 0.030 inches	0.25 or 0.762 mm

0.030 is the printer's default setting. Contact your service provider before using 0.010 thick cards.

Card material

For best results, use cards of the following types:

- PVC
- PET
- PET-G
- Polycarbonates
- ABS

Cleaning supplies

The printer uses the following cleaning supplies. For best results, keep cleaning supplies on hand.

Cleaning card	564729-164, pack of 10 cards
Magnetic head cleaning card	564729-166, pack of 10 cards
Card cleaning rollers	564729-122
Printer fan filters	564729-167, set of four replacement foam filters
Laminator fan filter	564731-133 and 564731-134, set of replacement filters

Site requirements

7

This section describes the operating environment recommended for your Datacard® RP90 Plus card printer and Datacard® RL90 card laminator.

It describes

- [“Site guidelines” on page 68](#)
 - [“Operating environment” on page 68](#)
 - [“Ventilation clearance” on page 69](#)
 - [“Storage Environment for supplies” on page 69](#)
- [“Printer specifications” on page 70](#)
- [“Laminator specifications” on page 71](#)

Site guidelines

Tips – Site selection

- Avoid locating the equipment in dirty or dusty environments.
- Do not place in areas susceptible to strong vibration or shock.
- Do not place the printer, optional laminator, or the supplies in direct sunlight.

When choosing a site for the printer and its supplies, consider these guidelines:

- Keep all dust, dirt, food, liquids, etc. away from the printer at all times.
- Do not use supplies or cards that have been dropped on the floor or have otherwise become contaminated.
- Keep paper and foreign materials off the printer.
- Place the printer on a stable platform; keep it off the floor.
- Place the printer away from direct sunlight.
- Place the printer away from heating ducts, blowers, or other air vents.
- Do not use the printer for purposes other than its intended use.
- When cleaning around the printer, prevent debris from entering the printer.
- Place the printer in a clean office environment, protected from any type of construction.
- Store all supplies in the original packaging until you load them in the printer. Keep the original packaging closed.
- Store all supplies in a clean, cool, and dry location.

Operating environment

The performance of the printer and optional laminator is strongly influenced by the installation location. Using the printer in areas below the recommended temperatures can cause retransfer errors, while using the printer in areas above the recommended temperatures can cause errors such as deformation and retransfer film errors. Consider the following recommendations if you need to move or relocate your printer.

Relative humidity: 35% to 70%

Temperature: 59° F to 86° F (15° C to 30° C)

Ventilation clearance

To ensure proper ventilation to the printer and laminator, maintain minimum clearance distances as shown.

Sides: 8" (20mm)

Back: 4" (10mm)

- Keep paper and foreign materials off the printer.
- Place the printer on a stable platform
- Do not place in areas susceptible to strong vibration or shock.
- Keep all dust, dirt, food, liquids, etc. away from the printer at all times.

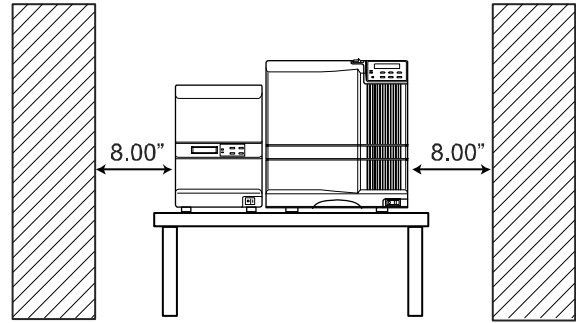

Storage Environment for supplies

Follow these guidelines when storing supply rolls:

- Store supplies in their original packaging until you are ready to use them.
- Choose a location away from direct sunlight, with a temperature between 41° F and 77° F (5° C and 25° C) with a maximum of 40% to 60% relative humidity.
- Do not store supplies in direct sunlight or high humidity locations.
- The print ribbon maintains its quality for about one year. For optimal card quality, purchase and store quantities that you can use up in less than a year.
- The print ribbon and card stock might require secure storage and tracking. Follow your policy for storing and tracking the supplies used to make cards.
- Supply rolls should be at room temperature when they are installed in the printer and used. If supplies are stored in a cooler environment than the printer, allow supplies to reach room temperature before using.
- If the printer will not be used for an extended period of time, remove supplies from the printer and store them with new supplies.

Printer specifications

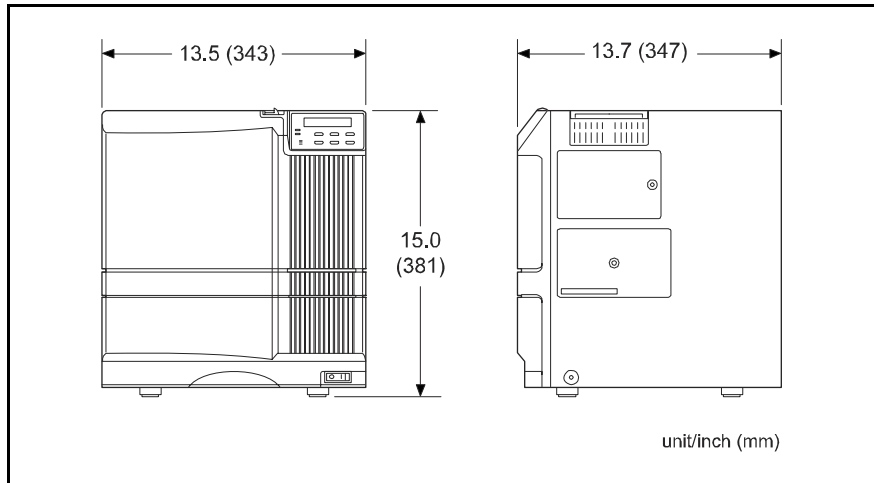

- Recording method:** Sublimation type retransfer
- Feed format:** Automatic feed
- Recording density:** 300 dpi
- Expression gradation:** 256 gradations for each color
- Printing time:** 29 sec. (single sided, excluding data transfer time)
- Interface:** USB 2.0
- Operating environment conditions**
- Temperature: 59°F to 86°F (15°C to 30°C)
- Humidity: 35% to 70% (no condensation)
- Storage environment conditions**
- Temperature: 5°F to 131°F (-15°C to 55°C)
- Humidity: 20% - 80%
- Power supply:** 100-120VAC or 220-240VAC (±10%)
- Current dissipation: 7.0A for 100V system and 5.0A for 200V system
- Weight:** 48.4 lbs (22kg) (Standard unit excluding built-in magnetic encoder)
- Sound level:** less than 70dB(A) according to DIN45635, part 19 (EN27779).

Laminator specifications

Tips – Electrical

- Check that the red INLET switch, located on the back of the laminator, is set for your input voltage.

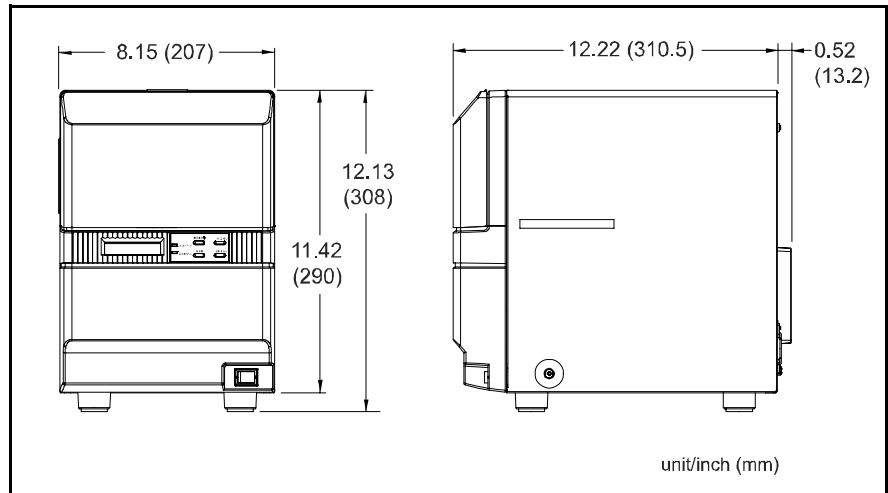

Transfer method	Halogen lamp built-in heat roller method
Transfer time	20 seconds. The time varies according to settings.
Usage environment	
Temperature:	59° F to 86° F (15° C to 30° C)
Storage environment	
Temperature:	5° F to 131°F (-15° C to 55° C)
Humidity:	30% to 70% (without condensation)
Power supply:	100-120VAC or 220-240VAC (±10%)
Power consumption:	Approximately 200 W
Weight:	17.6 lbs (8 kg)
Sound level:	less than 70dB(A) according to DIN45635, part 19 (EN27779).

Magnetic Stripe Encoding

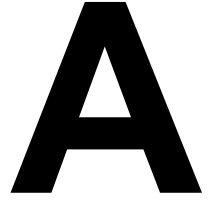

This section provides information about encoding magnetic stripe data. It includes:

- [“Inline Encoding” on page 74](#)
- [“Character Code Table” on page 75](#)

Inline Encoding

When each encoder setting of Print/Encode tab in the printer settings is checked, the encoder can be enabled. The encoding data is sent to the card printer through the printer driver using the prefix characters described in this section. This function is called “inline encoding”.

If the first three characters in a line are prefix characters (Tilde, “?” and numeral), the text that follow is recognized as encoding data. Encoding data is not printed on a card.

Prefix characters	Data format	character code table	Maximum Character Length
~?0	JIS type 2	7 unit code	69
~?1	ISO track 1 (International Air Transport Association — IATA)	6 unit code	76
~?2	ISO track 2 (American Bankers Association — ABA)	4 unit code	37
~?3	ISO track 3 (Thrift Third Standard — TTS)	4 unit code	104

Tip for success

- Data must be formatted with the same, continuous font.
- Only characters specified in the table on page 75 can be included. Using other characters will result in an error.
- The maximum number of characters does not include the three prefix characters.
- Make sure that the ID software or PC application does not process the encoding data as graphics.
- Magnetic stripe data must be on the first page of the card data.

Example

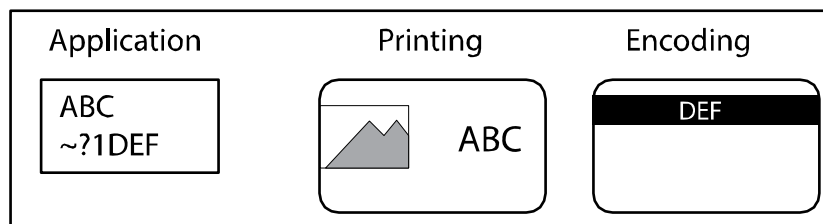

Character Code Table

The following table shows the usable ASCII character codes. The encoding data must use only allowed characters.

					b7	0	0	0	0	1	1	1	1
					b6	0	0	1	1	0	0	1	1
					b5	0	1	0	1	0	1	0	1
b4	b3	b2	b1		0	1	2	3	4	5	6	7	
0	0	0	0	0			0	@	P				p
0	0	0	1	1			!	A	Q	a			q
0	0	1	0	2			"	B	R	b			r
0	0	1	1	3			#	C	S	c			s
0	1	0	0	4			\$	D	T	d			t
0	1	0	1	5			%	E	U	e			u
0	1	1	0	6			&	F	V	f			v
0	1	1	1	7			'	G	W	g			w
1	0	0	0	8			(H	X	h			x
1	0	0	1	9)	I	Y	i			y
1	0	1	0	A	LF		*	:	J	Z	j		z
1	0	1	1	B			+	;	K	[k		{
1	1	0	0	C			,	<	L	\	l		
1	1	0	1	D			-	=	M]	m		}
1	1	1	0	E			.	>	N	^	n		~
1	1	1	1	F			/	?	O	_	o		DEL

4-unit code
6 unit code
7 unit code (except DEL)

Do not use the following start and end sentinels as encoding data.

	Start Sentinel (Hexadecimal)	End Sentinel (Hexadecimal)
4 unit code	; (3B)	? (3F)
6 unit code	% (25)	? (3F)
7 unit code	DEL (7F)	DEL (7F)

Compliance (FCC)

B

This section describes the regulatory compliance of the Datacard® RP90 Plus printer and the Datacard® RL 90 laminator. It includes the following:

- Regulatory compliance
 - Notice for USA (FCC notice)
 - Notice for Canada
 - Notice for Europe
- Notice to Users of Printers Equipped with Contactless Smart Card

Regulatory compliance

Notice for USA (FCC notice)

This equipment generates, uses, and can radiate radio frequency energy. If it is not installed and used in accordance with this instruction manual, it may interfere with radio communications. This equipment has been tested and found to be within the limits for Class B computing devices, pursuant to Subpart J of Part 15 of FCC rules, designed to provide reasonable protection against radio interference in a commercial environment. Operation of this equipment in a residential environment may possibly cause interference. In the event of interference, the user, at their own expense, will be required to take whatever measures are necessary to correct the problem.

This equipment has been tested and found to comply with the limits for a Class B digital device, pursuant to part 15 of the FCC Rules. These limits are designed to provide reasonable protection against harmful interference when the equipment is operated in a commercial environment. This equipment generates, uses, and can radiate radio frequency energy and, if not installed and used in accordance with the instruction manual, may cause harmful interference to radio communications. Operation of this equipment in a residential area is likely to cause harmful interference in which case the user will be required to correct the interference at his own expense.

Notice for Canada

This digital apparatus does not exceed the Class B limits for radio noise for digital apparatus set out in the Radio Interference Regulations of the Canadian Department of Communications.

Le présent appareil numérique n'émet pas de bruits radioélectriques dépassant les limites applicables aux appareils numériques de la classe B prescrites dans le Règlement sur le brouillage radioélectrique édicté par le ministère des Communications du Canada.

The term "IC:" before the radio certification number only signifies that Industry Canada Technical specifications were met.

Notice for Europe

We hereby certify that the Datacard® RP90 Plus printer complies with EMC Directive 89/336/EEC and R&TTE Directive 1999/5/EC. This printer conforms to Class B of EN 55022 and to EN 301 489-5. Operation of this equipment in a residential environment may possibly cause interference. In the event of interference, the user, at their own expense, will be required to take whatever measures are necessary to correct the problem.

Notice to Users of Printers Equipped with Contactless Smart Card

The contactless smart card reader emits radio-frequency waves and must be used as installed and recommended by Datacard Group. You may not modify the reader or how it is used without the written permission of Datacard Group. You may not operate the printer after modifying the reader or its method of operation.

Datacard Group

11111 Bren Road West
Minnetonka, MN 55343-9015
952.933.1223
952.933.7971 FAX
www.datacard.com